



INSTALLATION INSTRUCTIONS

BUMPER

Part Number: 81910

Applications: 2009+ Honda Rancher

Your safety, and the safety of others, is very important. To help you make informed decisions about safety, we have provided installation and operating instructions and other information on labels and in this guide. This information alerts you to potential hazards that could hurt you or others. It is not possible to warn you about all potential hazards associated with this product, you must use your own good judgment.

CARELESS INSTALLATION AND OPERATION CAN RESULT IN SERIOUS INJURY OR EQUIPMENT DAMAGE. READ AND UNDERSTAND ALL SAFETY PRECAUTIONS AND OPERATING INSTRUCTIONS BEFORE INSTALLING AND OPERATING THIS PRODUCT.

This guide identifies potential hazards and has important safety messages that help you and others avoid personal injury or death. **WARNING** and **CAUTION** are signal words that identify the level of hazard.

These signal words mean:

WARNING signals a hazard that *could* cause serious injury or death, if you do not follow recommendations. **CAUTION** signals a hazard that *may* cause minor to moderate injury, if you do not follow recommendations.

This guide uses **NOTICE** to call attention to important mechanical information, and **Note**: to emphasize general information worthy of special attention.

WARNING

INJURY HAZARD

Failure to observe these instructions could lead to severe injury or death.

- ❑ **Always** use extreme caution when drilling on any vehicle. Make sure that all fuel lines, brake lines, electrical wires, and other objects are not punctured or damaged when / if drilling on the vehicle. Thoroughly inspect the area to be drilled (on both sides of material) prior to drilling, and relocate any objects that may be damaged. Failure to inspect the area to be drilled may result in vehicle damage, electrical shock, fire or personal injury.
- ❑ **Always** wear safety glasses when installing this kit. A drilling operation will cause flying metal chips. Flying chips can cause eye injury.
- ❑ **Always** use extreme caution when cutting and trimming during fitting.
- ❑ **Always** remove jewelry and wear eye protection.
- ❑ **Never** lean over battery while making connections.
- ❑ **Never route electrical cables:**
 - Across any sharp edges.
 - Through or near moving parts.
 - Near parts that become hot.
- ❑ **Always** insulate and protect all exposed wiring and electrical terminals.
- ❑ **Always** install terminal boots as directed in installation instructions.
- ❑ **Always** use appropriate and adequate care in lifting components into place.
- ❑ **Always** insure components will remain secure during installation and operation.
- ❑ **Always** tighten all nuts and bolts securely, per the installation and operation.
- ❑ **Always** perform regular inspections and maintenance on the bumper and related hardware.
- ❑ **Never** operate this **WARN** product with damaged or missing parts.

⚠ Caution
Moving Parts Entanglement Hazard
Failure to observe these instructions could lead to minor or moderate injury.
<input type="checkbox"/> Always take time to fully read and understand the installation and Operations Guide included with this product. <input type="checkbox"/> Never operate this product if you are under 16 years of age. <input type="checkbox"/> Never operate this product when under the influence of drugs, alcohol or medications.
Read installation and operating instructions thoroughly.

Notice
Equipment Damage
<input type="checkbox"/> Always refer to the Installation and Specification Guide, supplied in the winch kit, for all wiring schematics and specific details on how to wire this WARN product to your vehicle.
Read installation and operating instructions thoroughly.

NOTE: This bumper includes mounting holes for WARN winch and trail lights, which are sold separately.

I. TABLE OF CONTENTS

Tools Required	page 2
Fastener Torque Specifications	page 2
Parts List	page 3
Installation	page 4
Maintenance/Care	page 5

II. TOOLS REQUIRED

- Ratchet
- Sockets 7/16 and 1/2

III. FASTENER TORQUE SPECIFICATIONS

1/4 & M6	8 lb. ft. (10.8 N-m)
5/16 & M8	17 lb. ft. (12.5 N-m)
3/8 & M10	30 lb. ft. (40.7 N-m)
7/16	50 lb. ft. (67.8 N-m)
1/2	75 lb. ft. (101.7 N-m)

IV. PARTS LIST

<i>Ref.</i>	<i>Description</i>	<i>Qty</i>
A1	Rancher Bumper	1
B1	1/4-20 U-bolt	2
B2	1/4 inch flat washer	4
B3	1/4 -20 lock nut	4
B4	5/16-18 U-bolt	2
B5	5/16 inch flat washer	4
B6	5/16-18 lock nut	4

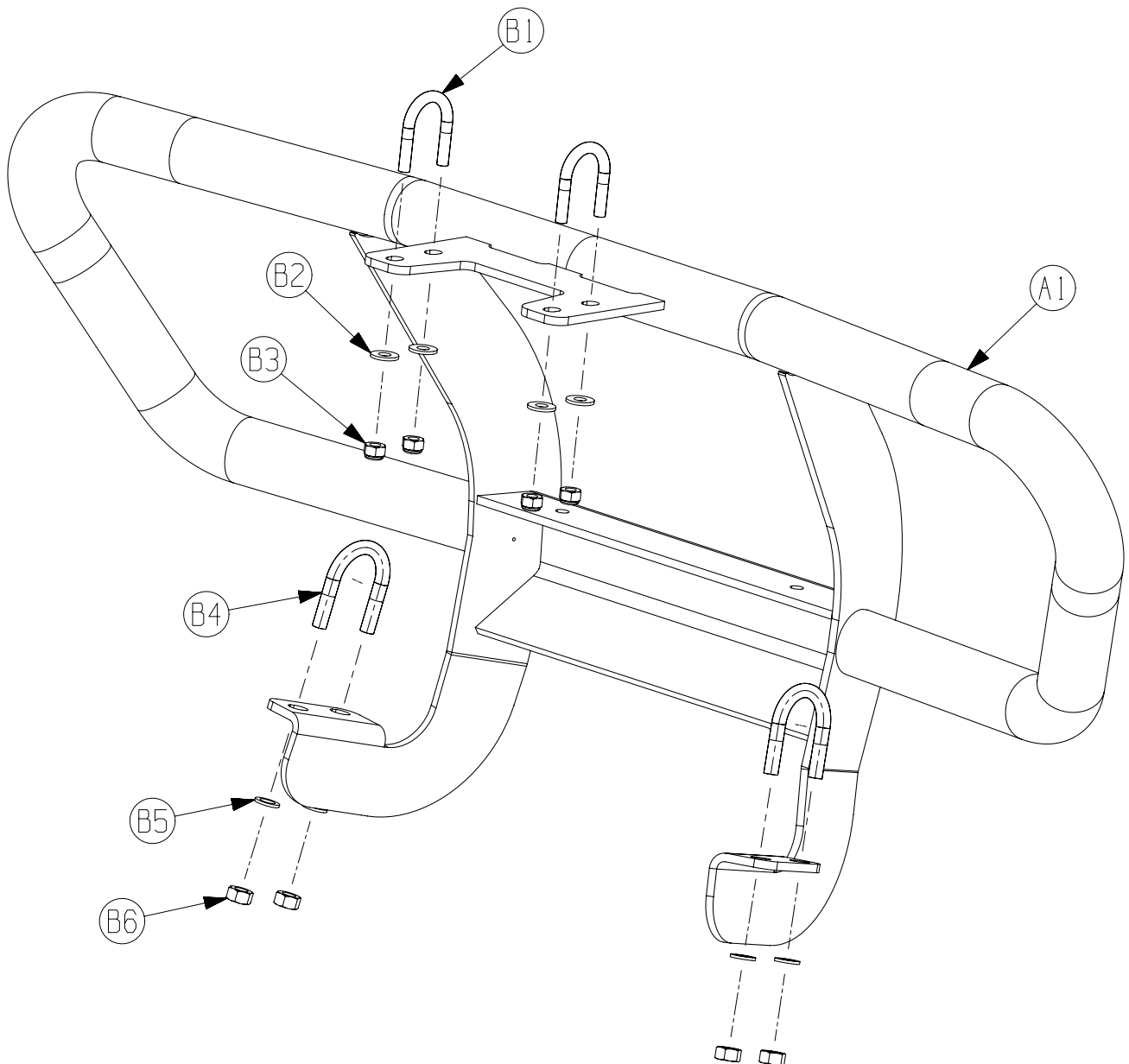

V. INSTALLATION

1. Loosely fasten the top bumper mounting tab to the underside of vehicle rack using 1/4-20 u-bolts, 1/4 inch flat washers and 1/4-20 lock nuts. See figure 1.



Figure 1

2. Loosely secure bottom bumper mount tabs to lower factory bumper tube. Use 5/16-18 u-bolts with 5/16 flat washers and 5/16 lock nut. See figure 2.



Figure 2

3. Center bumper on vehicle and tighten down all hardware.



Figure 3

 WARNING

FAILURE TO SECURELY TIGHTEN ALL BOLTS ON THE BUMPER CAN RESULT IN PRODUCT FAILURE WHICH MAY RESULT IN VEHICLE DAMAGE AND OPERATOR INJURY OR DEATH. DOUBLE CHECK THAT ALL BOLTS ARE SECURELY TIGHTENED PRIOR TO USE.

VI. MAINTENANCE/CARE

1. Inspect all parts on the bumper and related hardware prior to each use. Replace all hardware that appears rusted or deformed.
2. Inspect all nuts and bolts on the bumper, and related hardware prior to each use. Tighten all nuts that appear to be loose. Stripped, fractured, or bent bolts or nuts need to be replaced.
3. Check all moving or rotating parts. Remove debris that may inhibit the part from moving freely.

 WARNING

PERFORM REGULAR INSPECTIONS ON THE BUMPER AND RELATED HARDWARE. FAILURE TO FOLLOW THIS WARNING MAY CAUSE VEHICLE DAMAGE AND OPERATOR INJURY OR DEATH.