

Anbauanleitung Seilwindenanbausatz Mitsubishi Pajero V60 und V80

Best.-Nr.: 16 -3840

AL: 1080 – 03



**Hier sehen sie den fertig montierten Seilwindenanbausatz.
Bevor sie mit der Montage beginnen, lesen sie bitte diese Anleitung
und das Benutzerhandbuch der Seilwinde gut durch.**

Achtung:

Bei Fahrten im öffentlichen Straßenverkehr muß das Rollenseilfenster mit der Kunststoffabdeckung Best.nr.: **15 – 899** abgedeckt werden.

Stückliste

Seilwindenanbausatz Mitsubishi Pajero V 60 und V80

Best.nr.: 16 – 3840 bzw. Z 4245384

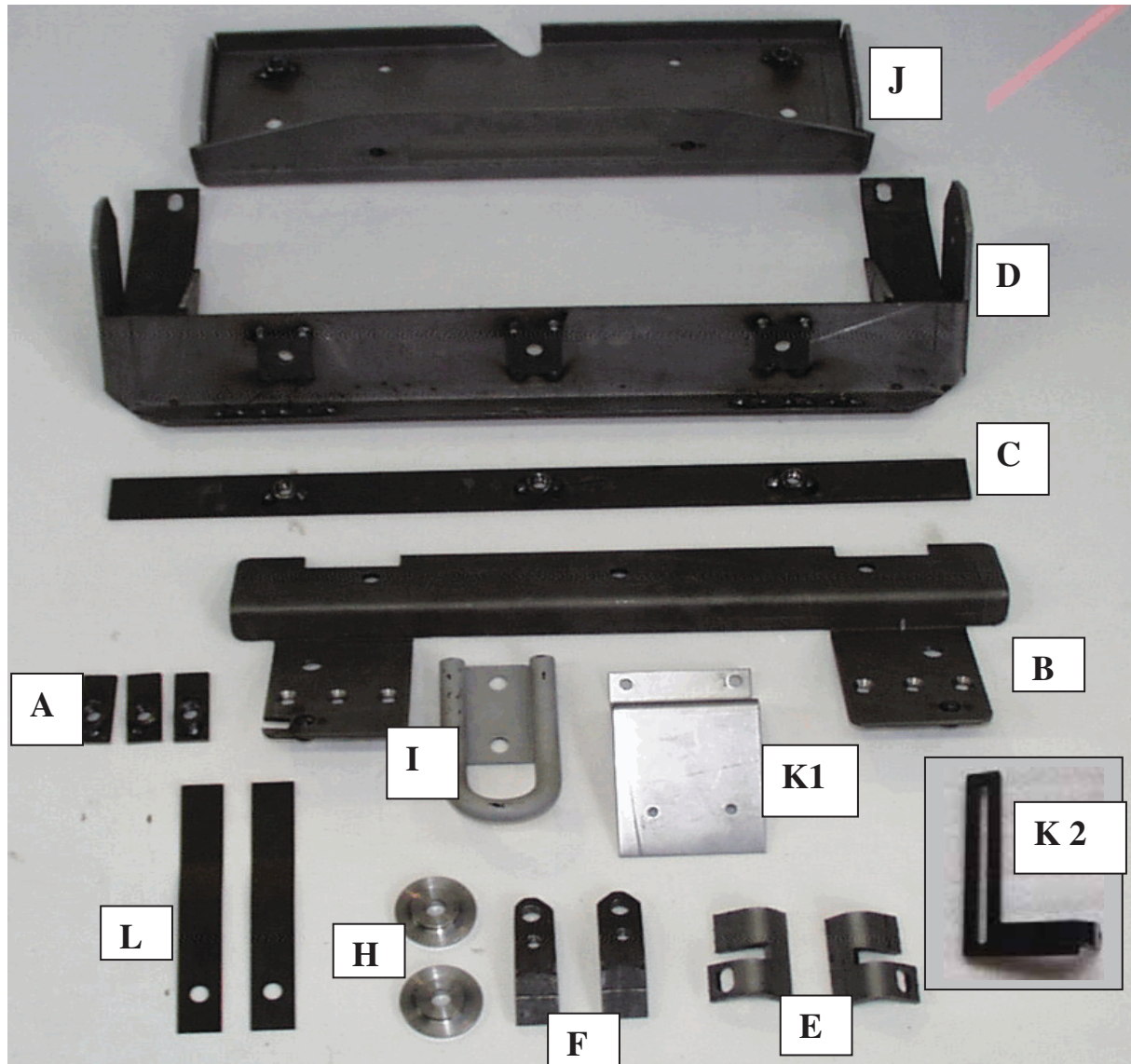

3 x Gewindeplatte (A)
1 x Grundträger hinten (B)
1 x Flacheisen mit Gewinde (C)
1 x Grundträger vorne (D)
2 x Distanzplatte für Stabilisator (E)
2 x Gewindeplatte (F)

2 x Scheibe abgedreht (H)

1 x Abschleppöse (I)
1 x Seilwindenkassette (J)

1 x Schaltkastenhalter V 60 (K 1)
1 x Schaltkastenhalter V 80 (K 2)
2 x Kennzeichenhalter (L)

1 x Kabelsatz 16 – 387 K
1 x Steckdose (2 m) 1 – 39744

1x Kunststoffabdeckung 15 – 899
1 x Gutachten
1 x Anbauanleitung AL 1080

7 x Schraube M 12 x 30
3 x Schraube M 12 x 40
2 x Schraube M 12 x 60
2 x Mutter M 12
14 x U – Scheibe M 12
12 x Federring M 12

1 x Schraube M 10 x 30
3 x schraube M 10 x 25
4 x Schraube M 10 x 1.25 x 40
8 x U – Scheibe M 10
8 x Federring M 10

6 x Senkkopfschraube M 8 x 20

2 x Schraube M 5 x 25
2 x Mutter M 5
4 x U – Scheibe M 5
2 x Federring M 5

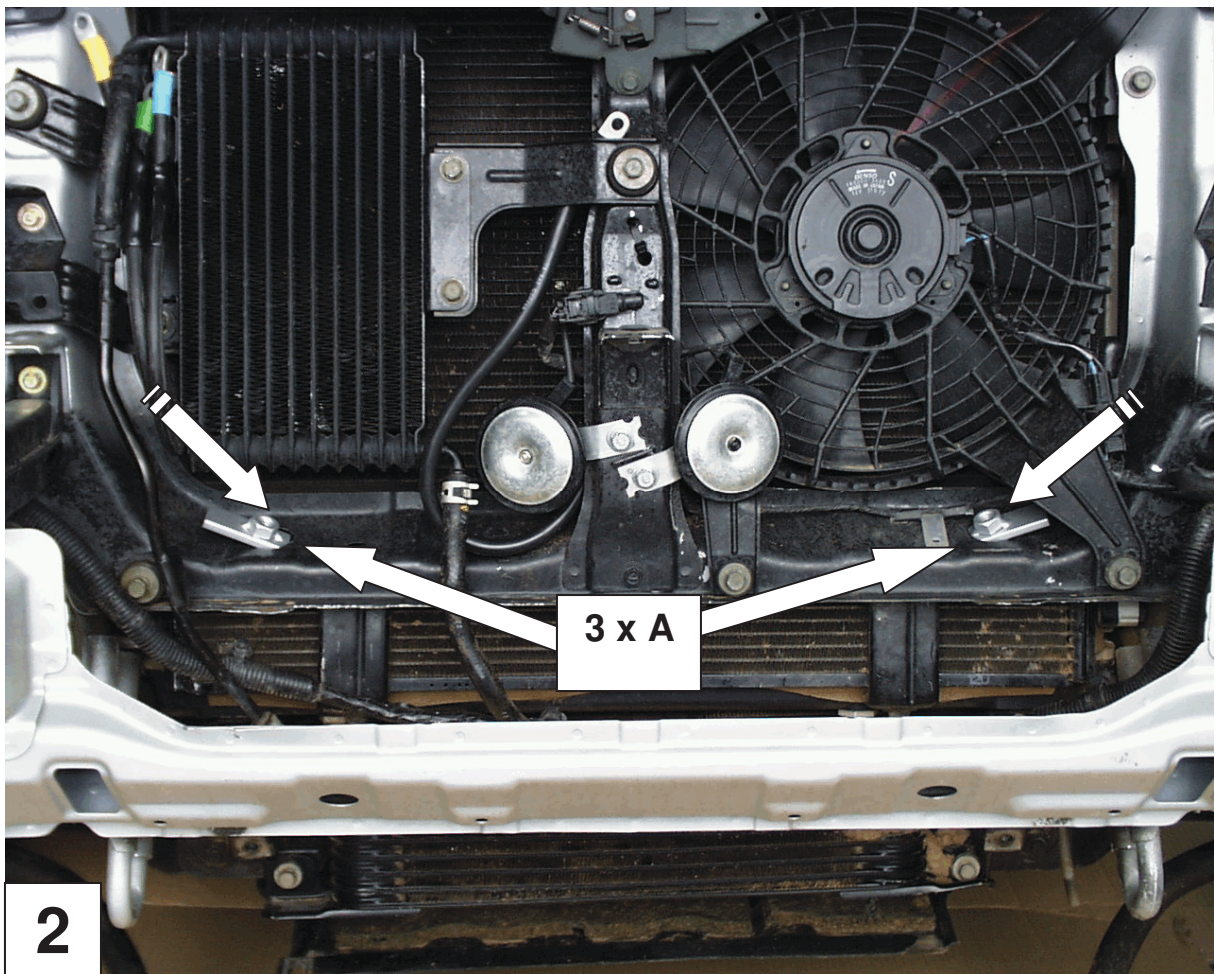
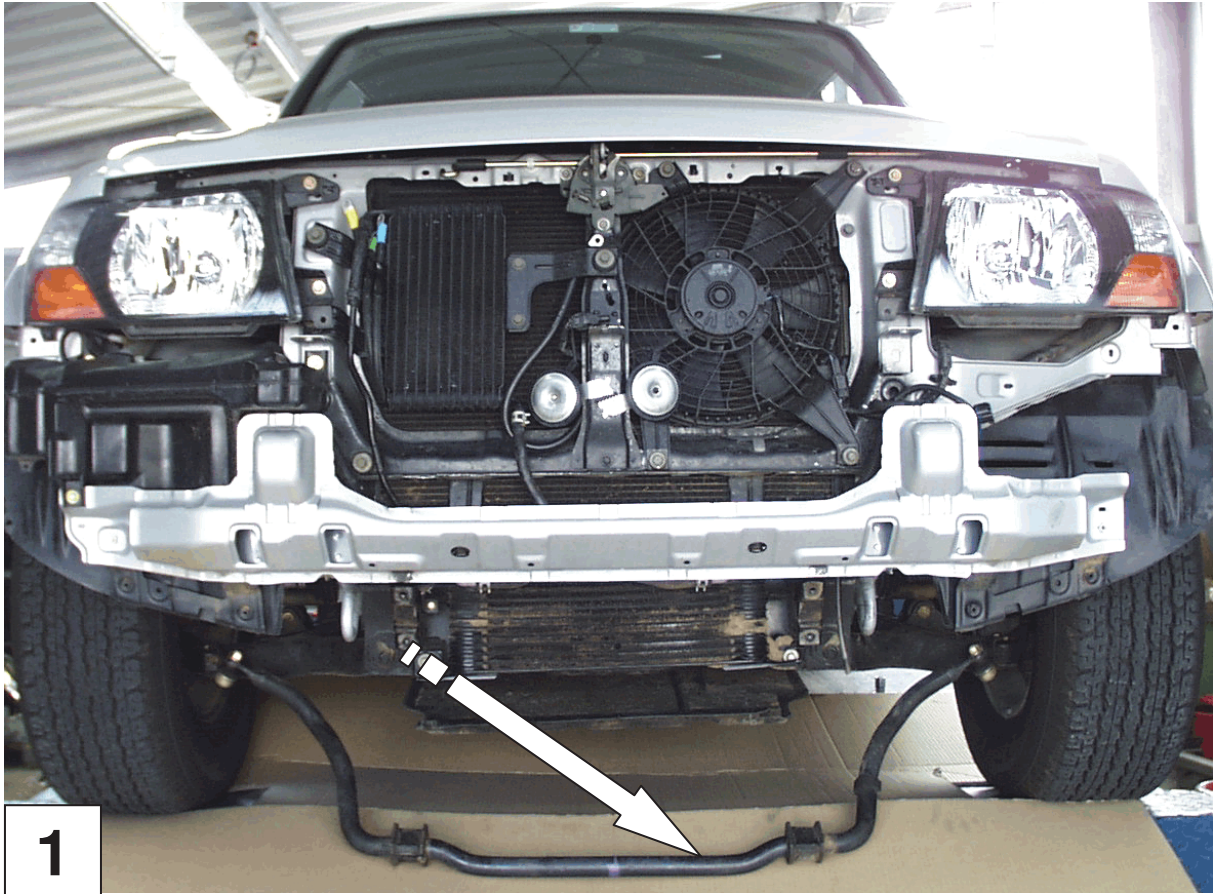

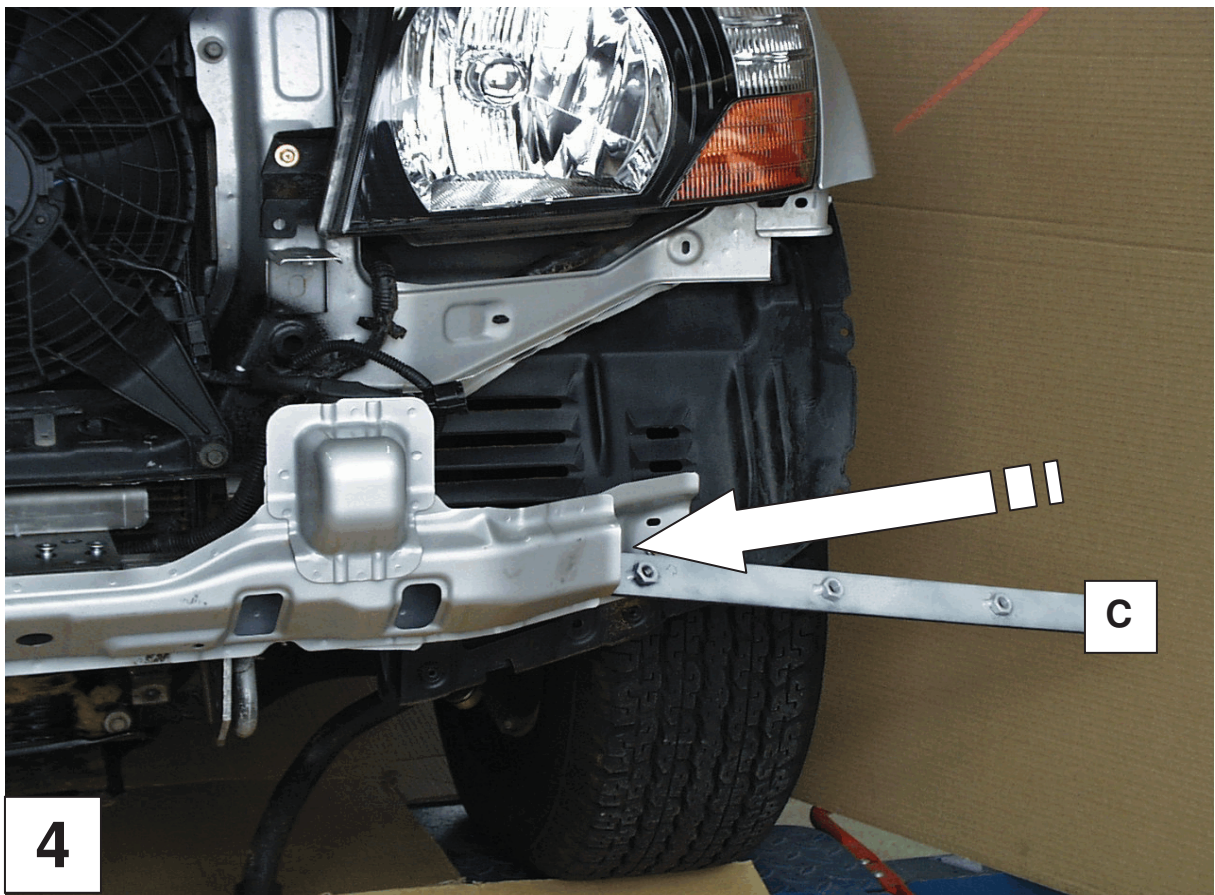
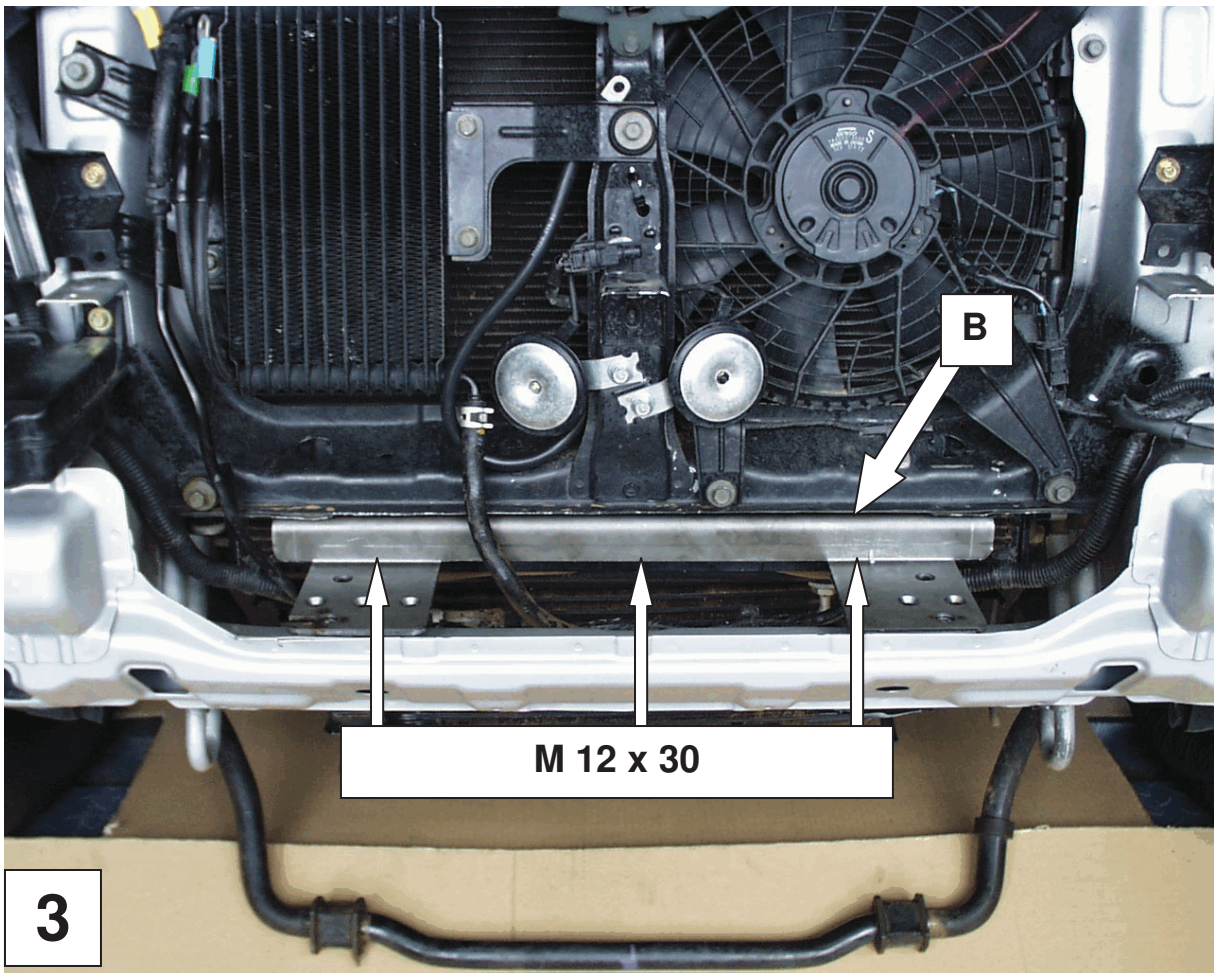

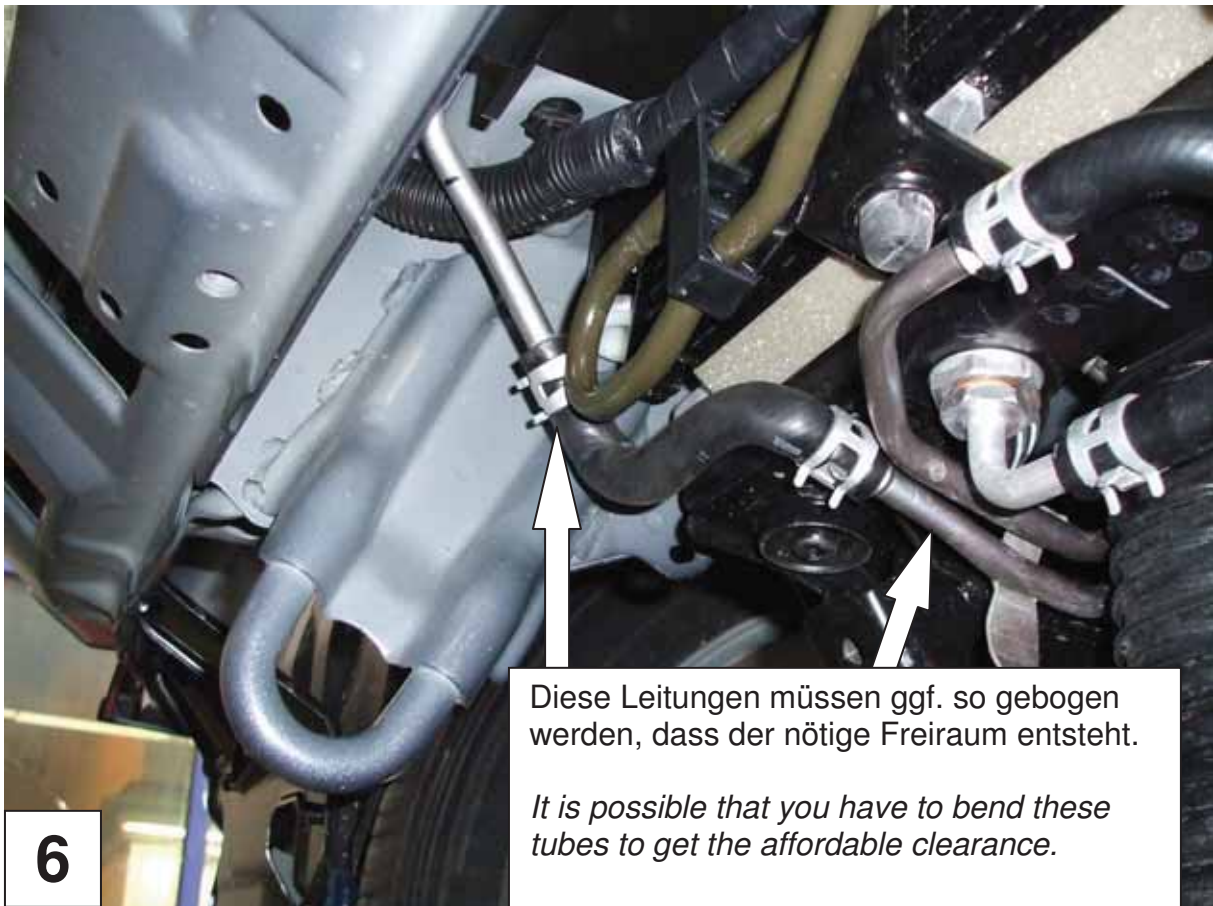
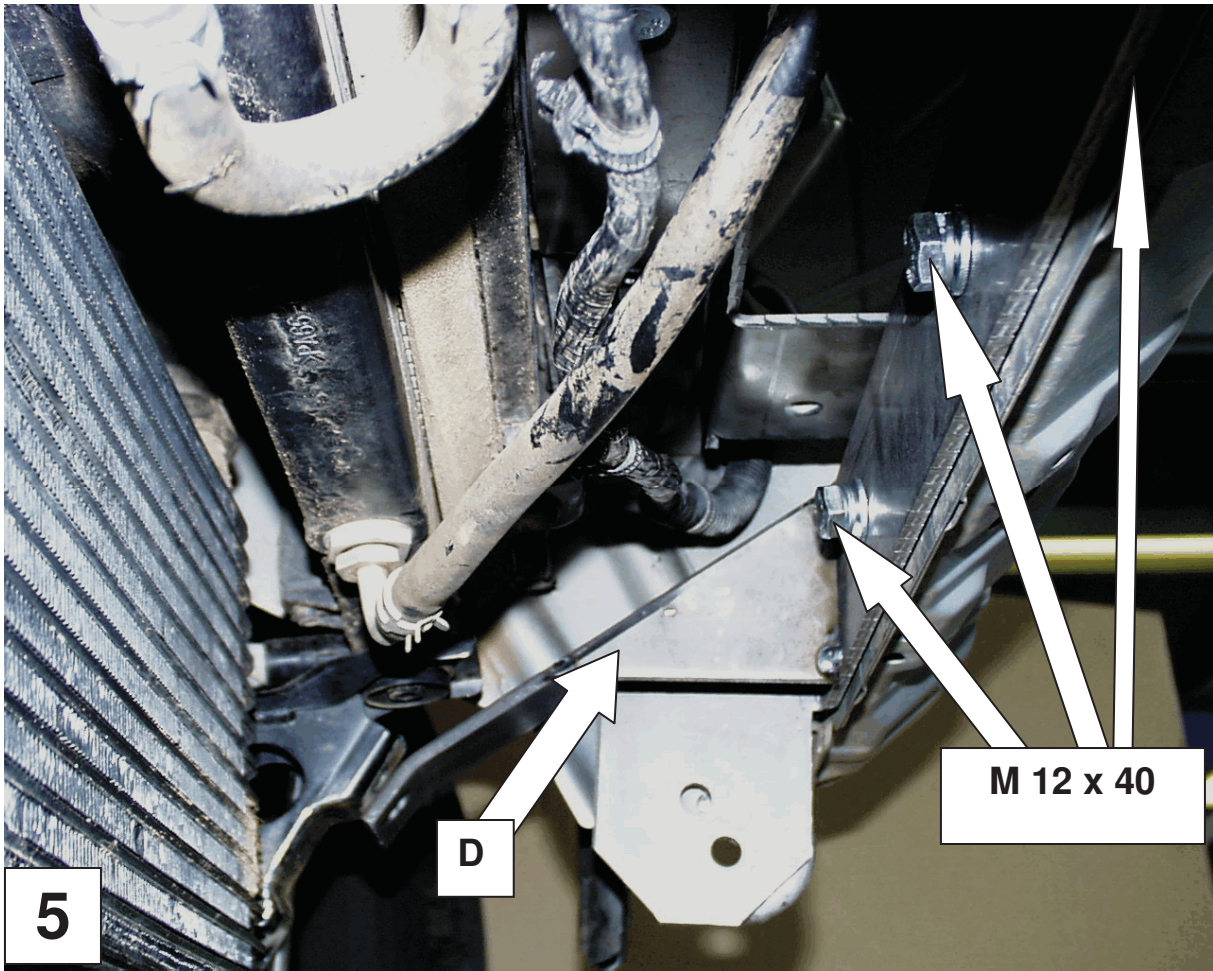

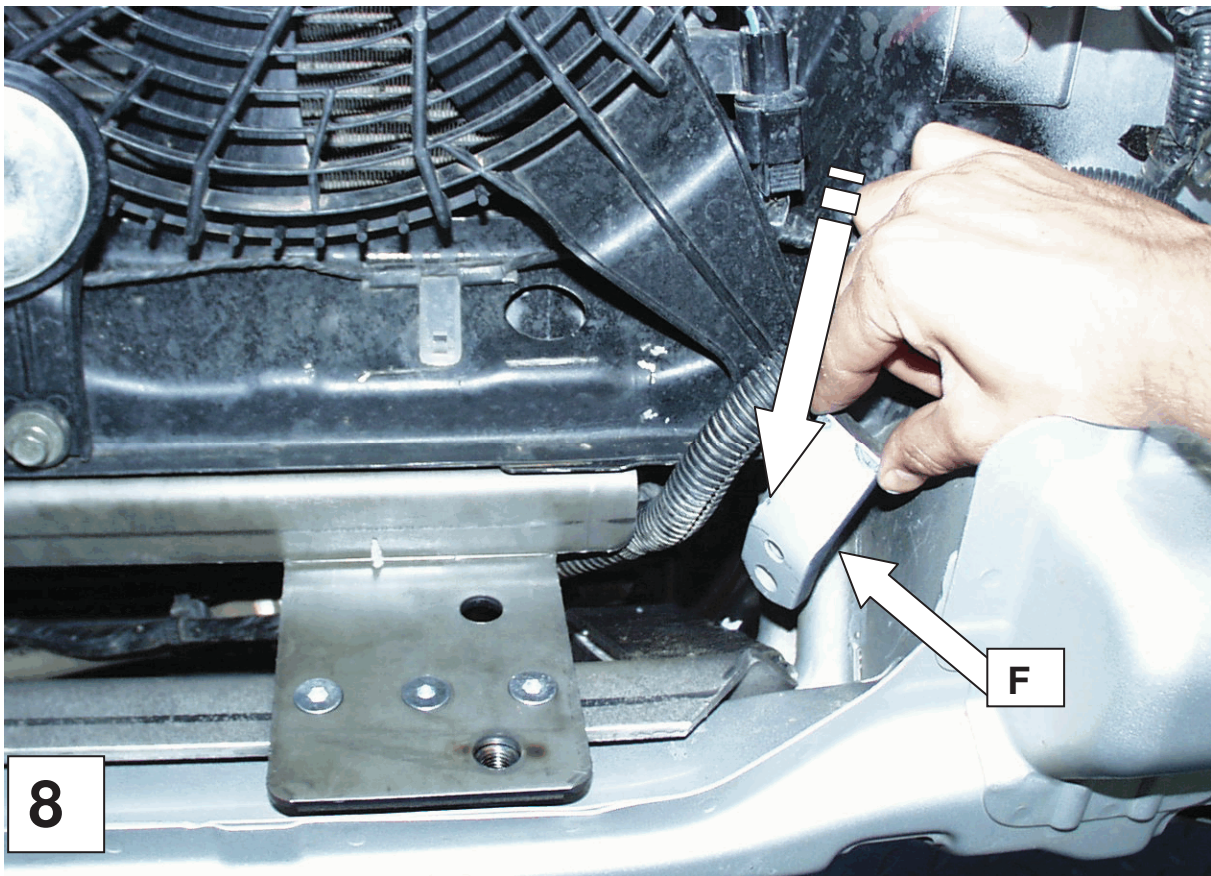
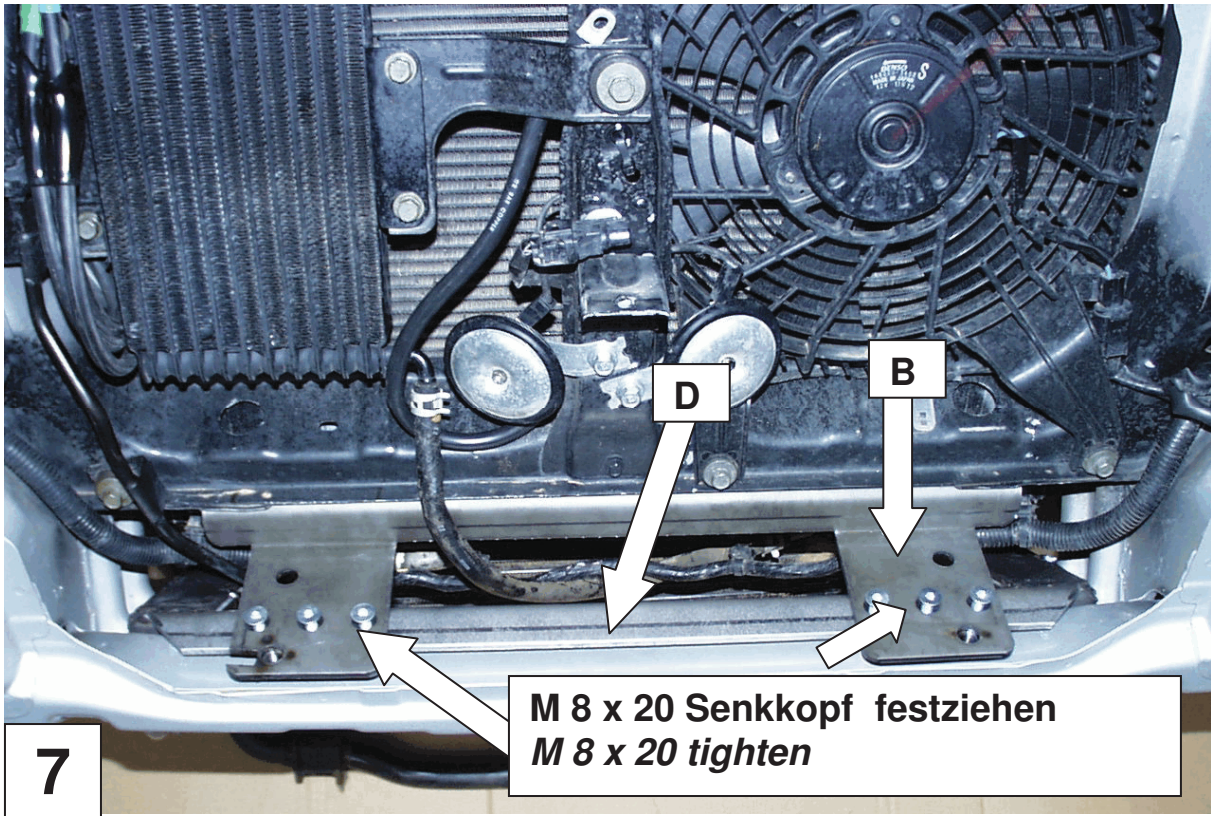

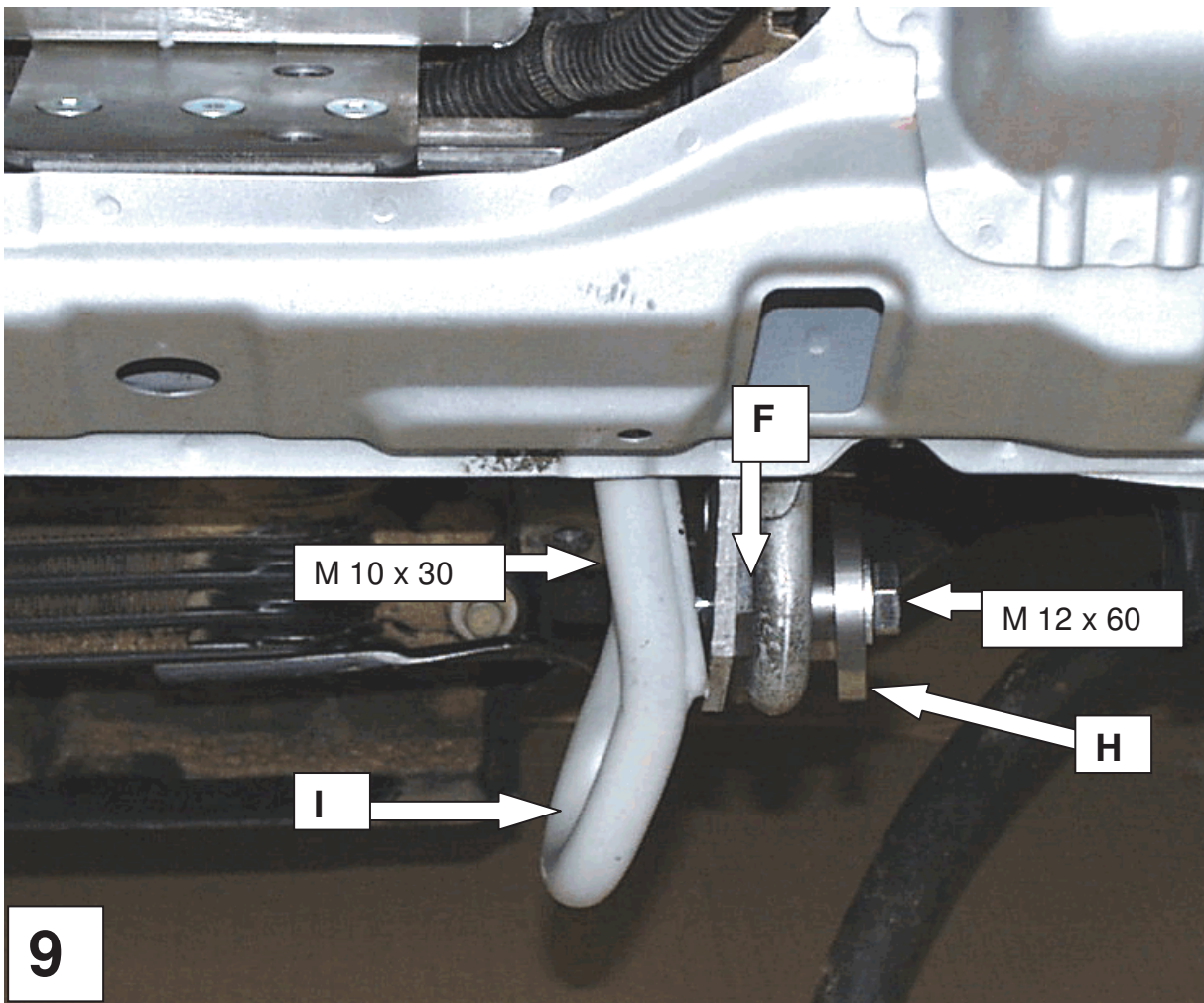

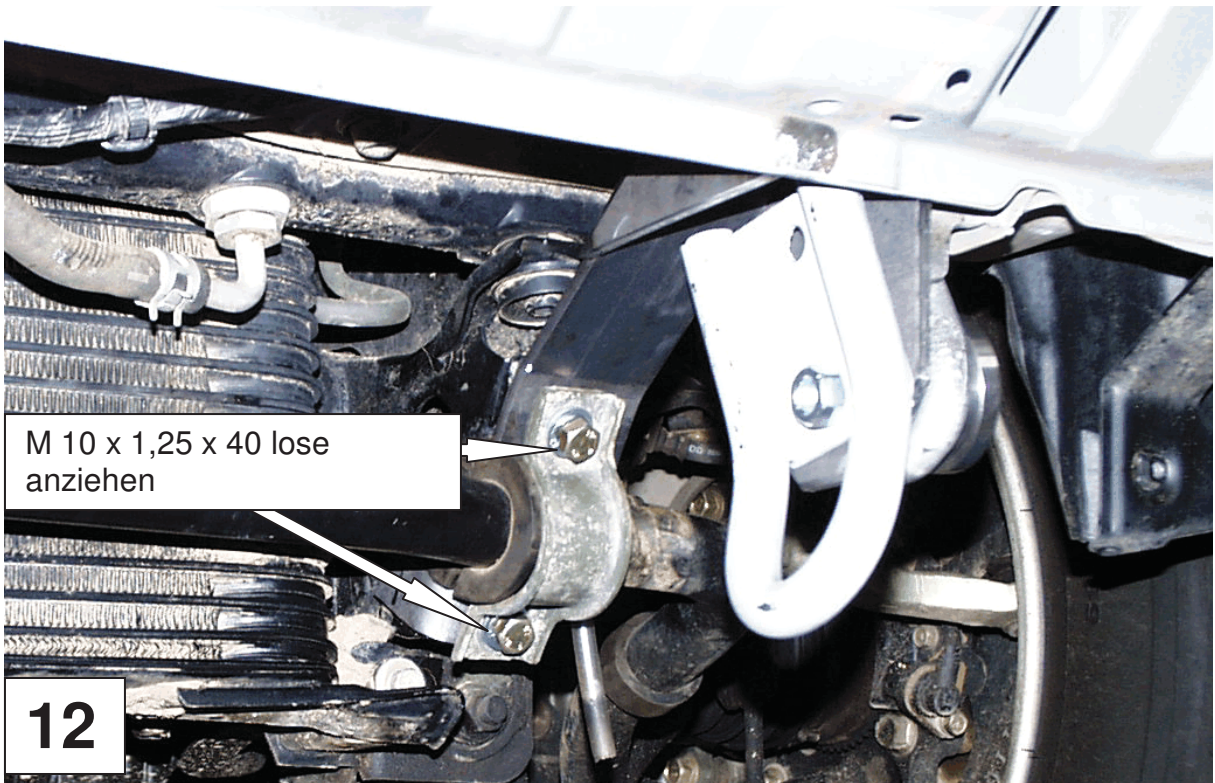
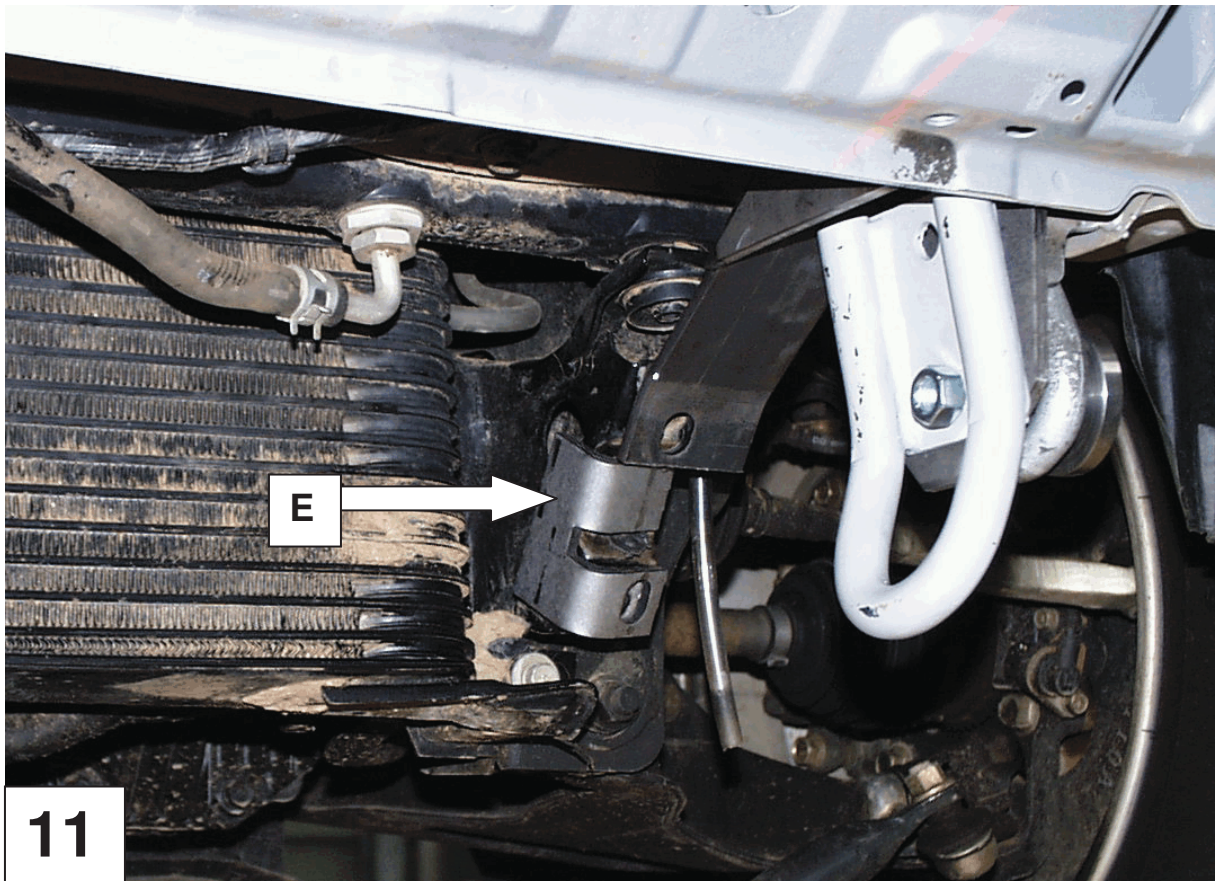

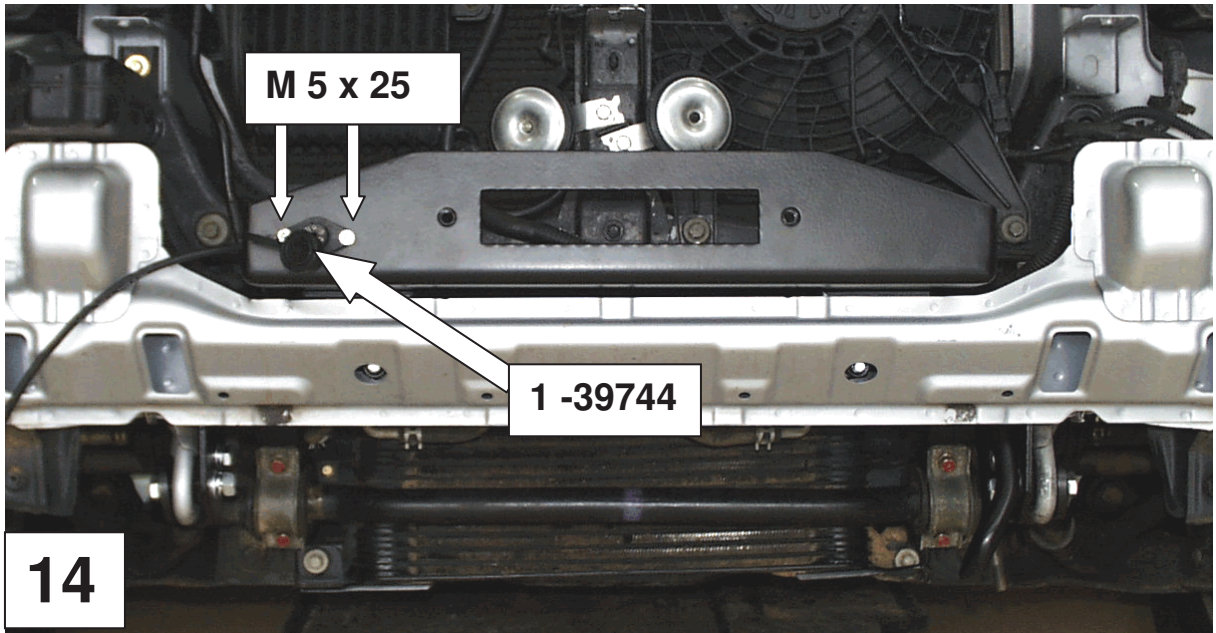
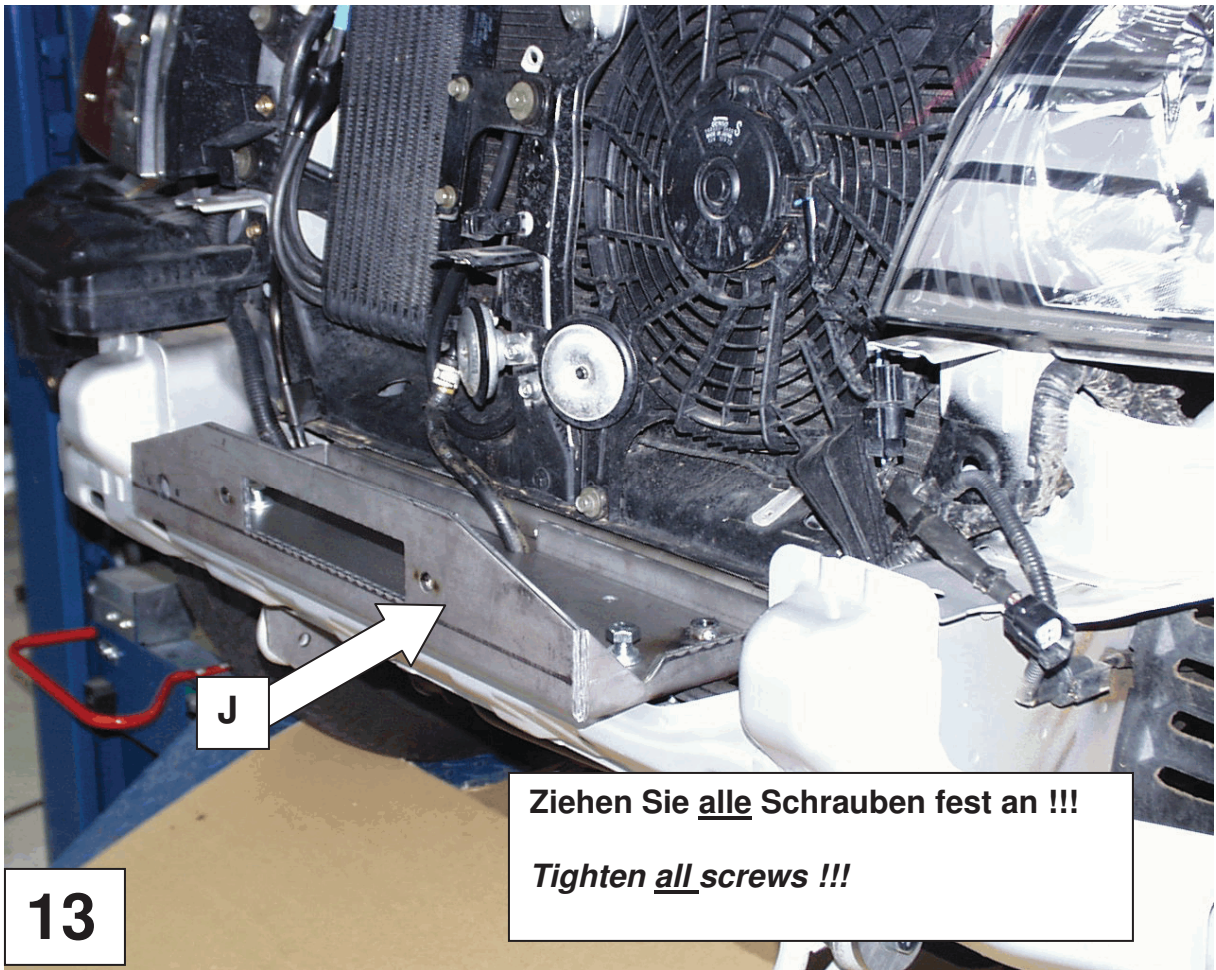

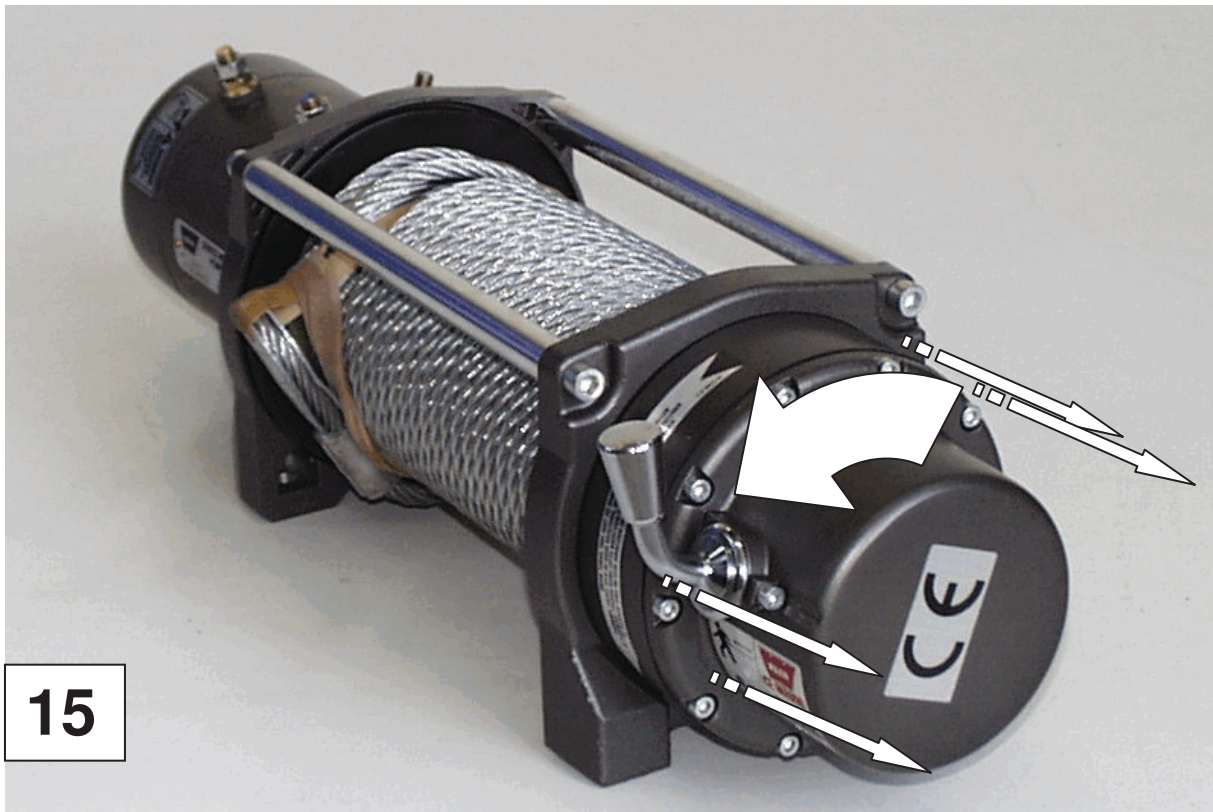

15

Punkt 16 bis 22 sind nur für V60 Modelle
Step 16 to 22 is for V 60 models only

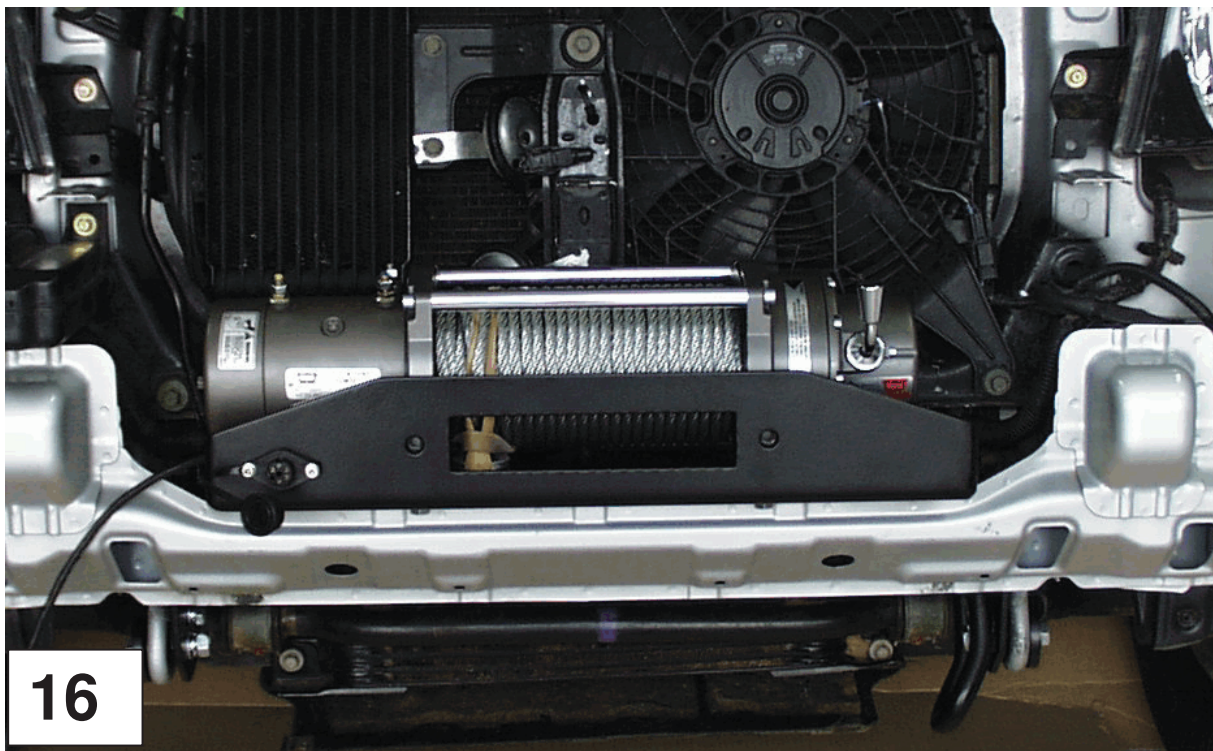

16

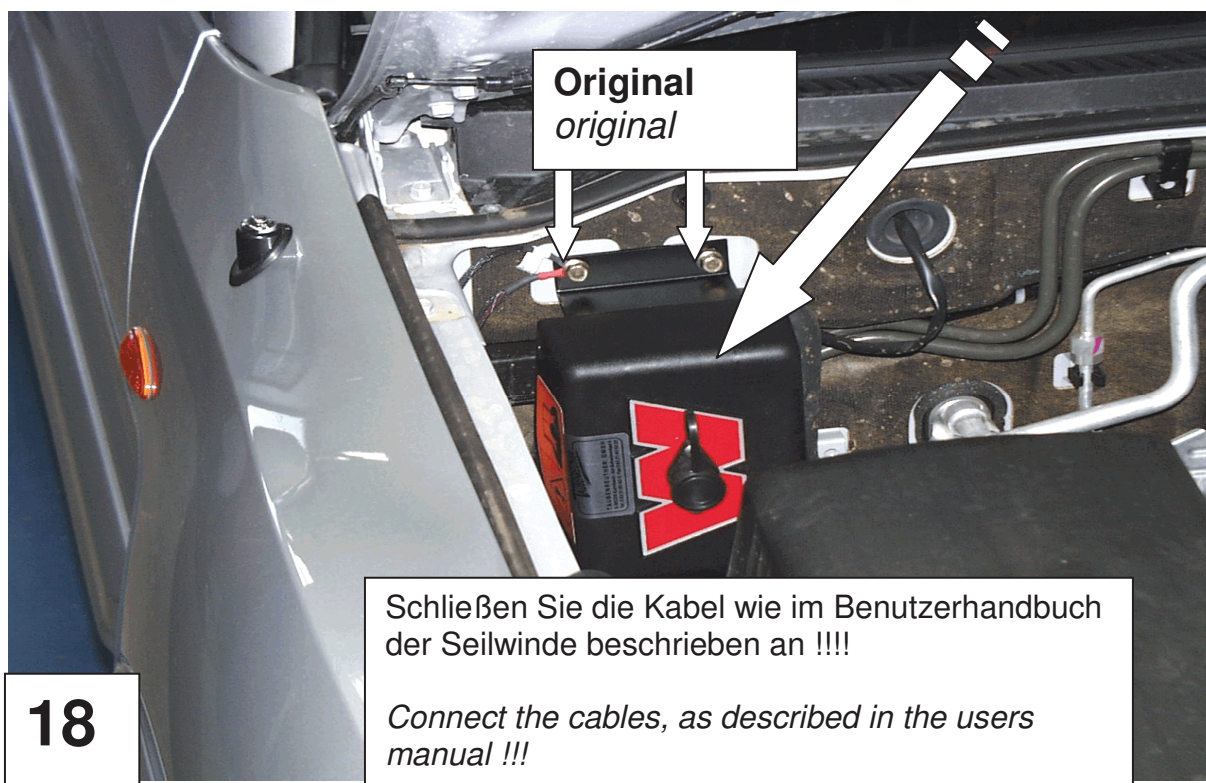
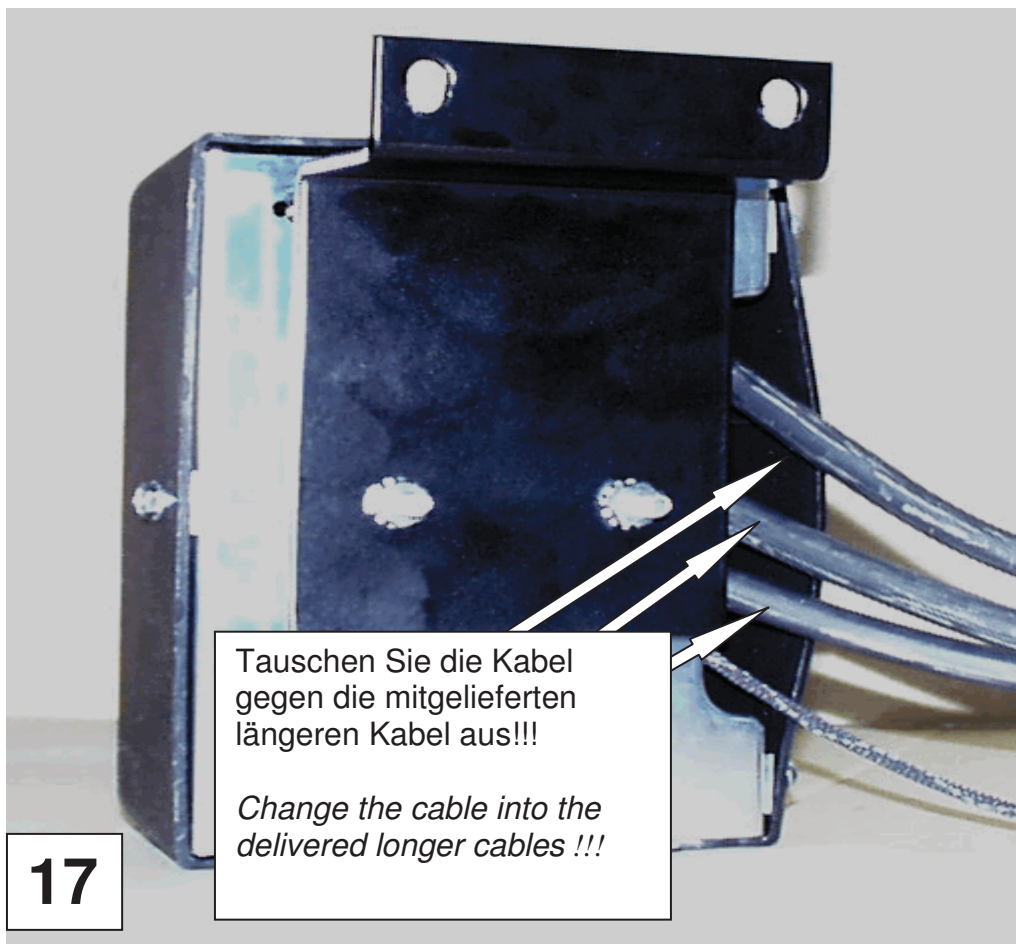

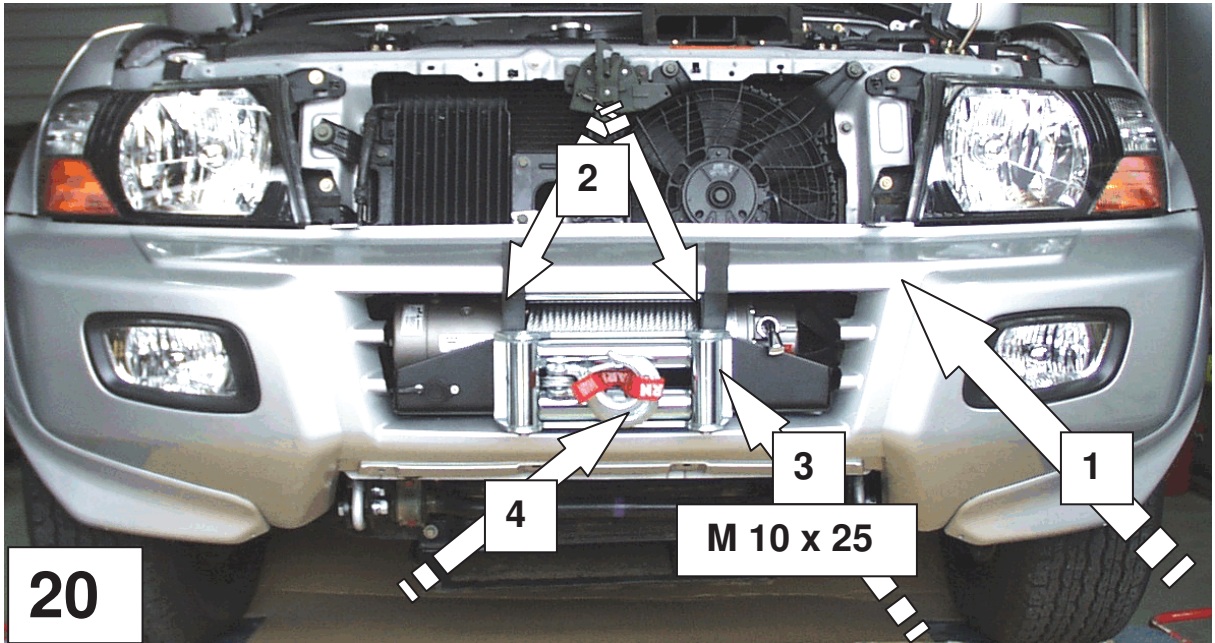
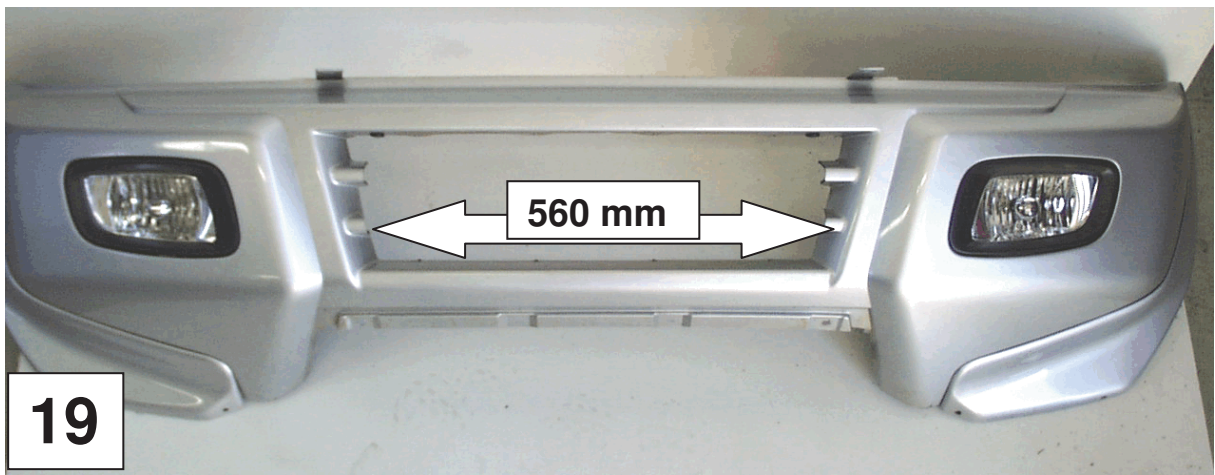



Die Punkte 23 bis 39 sind für V 80 Modelle
Points 23 to 39 are for V 80 models only







26

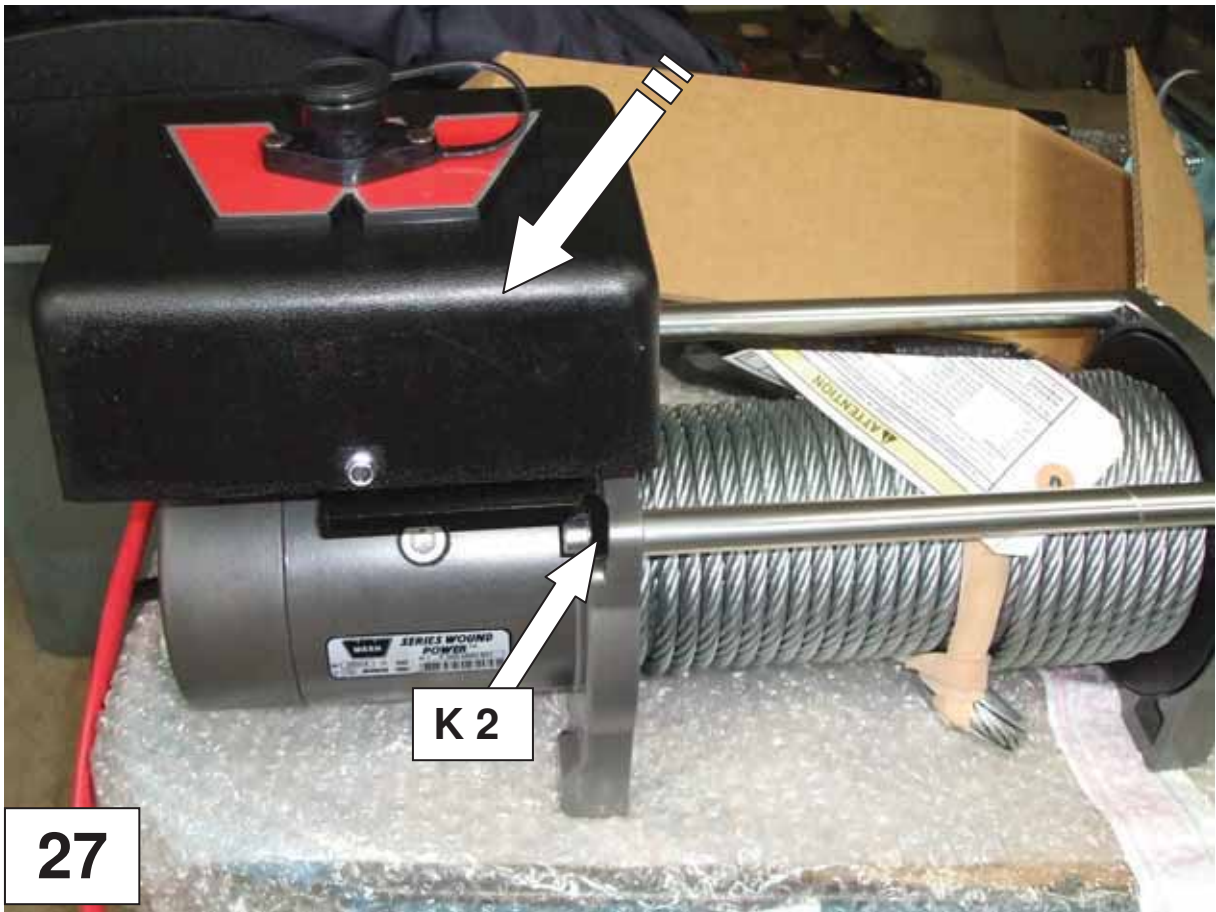

27



28

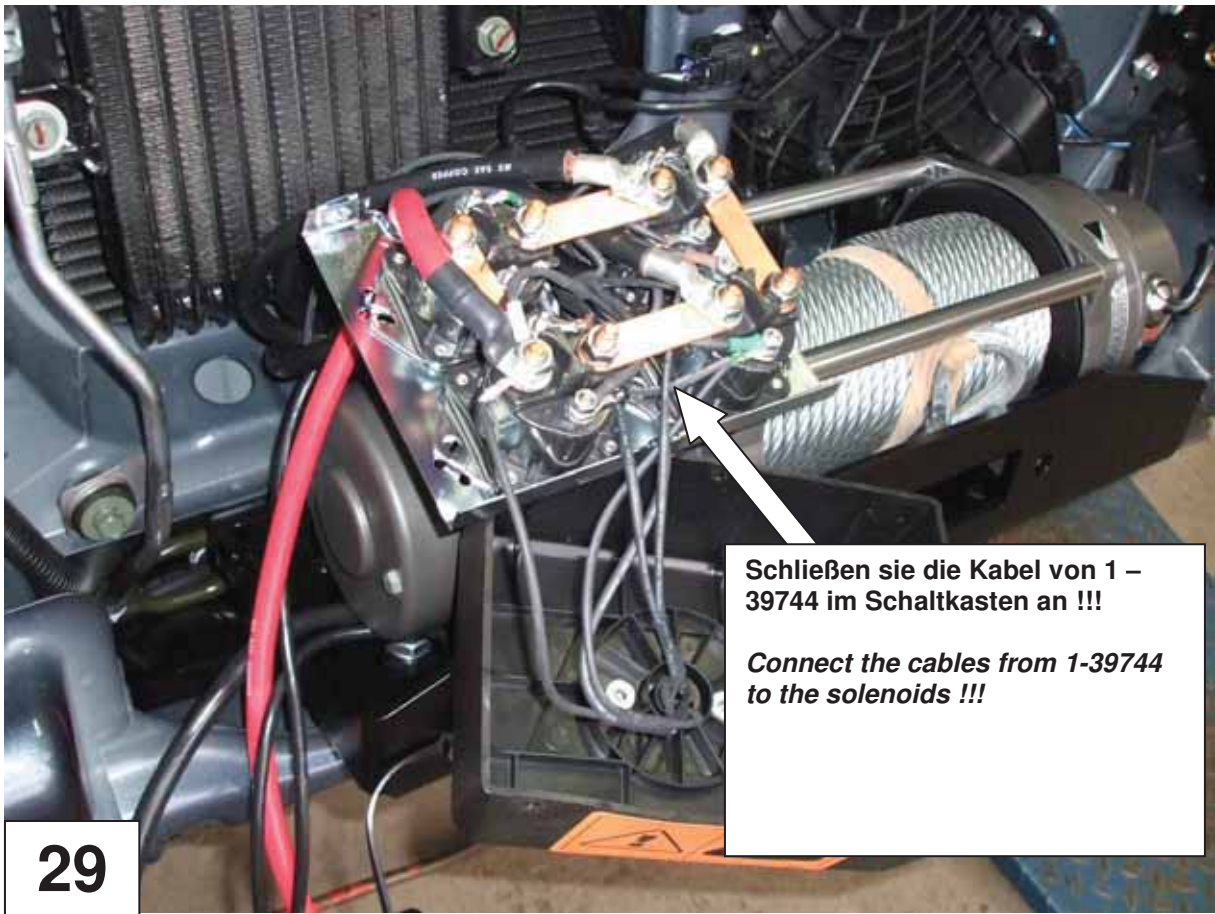

29

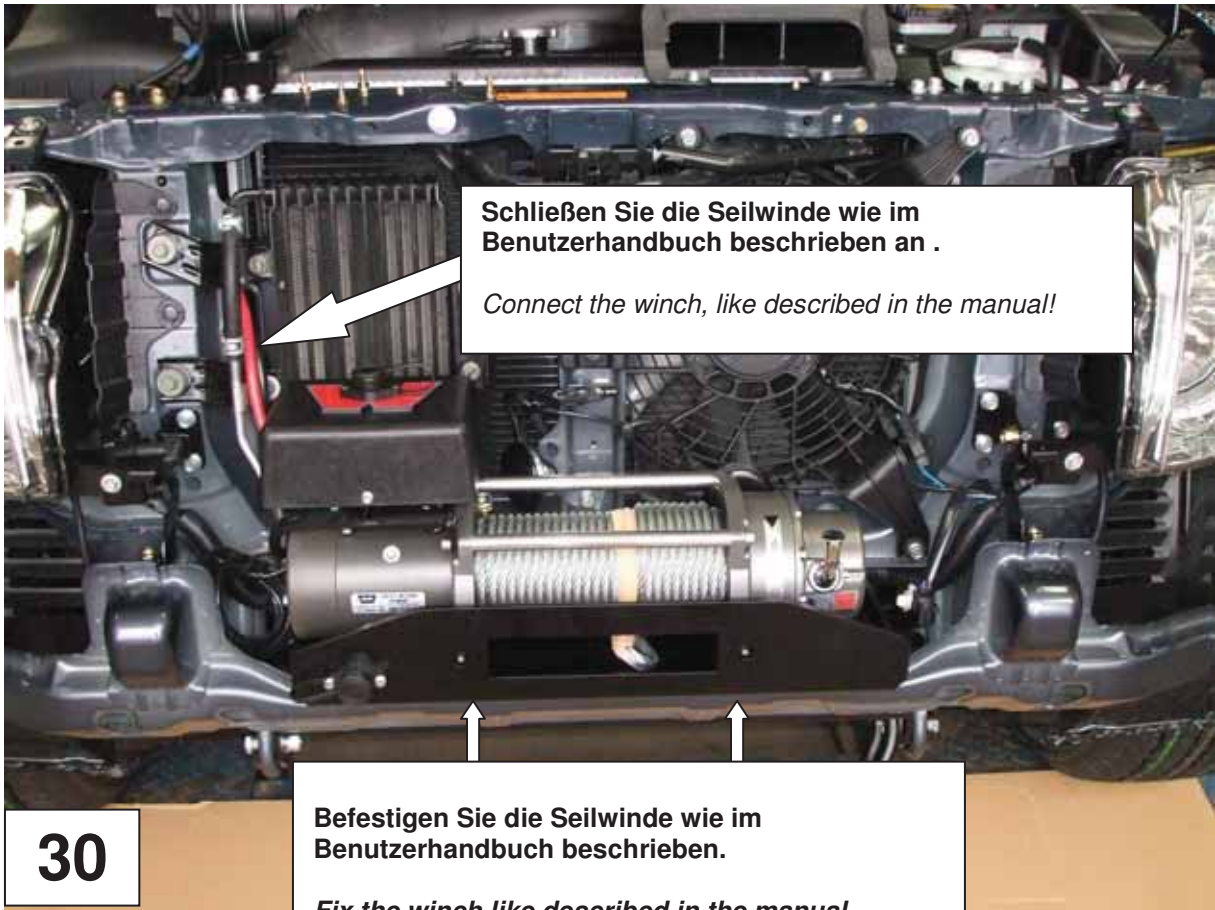



32



33

