





Warnings and Cautions



As you read these instructions, you will see WARNINGS, CAUTIONS, NOTICES and NOTES. Each message has a specific purpose. WARNINGS are safety messages that indicate a potentially hazardous situation, which, if not avoided could result in serious injury. CAUTIONS are safety messages that indicate a potentially hazardous situation which, if not avoided, could result in minor or moderate injury. A CAUTION may also be used to alert against unsafe practice. CAUTIONS and WARNINGS identify the hazard, indicate how to avoid the hazard, and advise of the probable consequence of not avoiding the hazard. NOTICES are messages to avoid property damage. NOTES are additional information to help you complete a procedure. **PLEASE WORK SAFELY!**

 WARNING		
		
MOVING PARTS ENTANGLEMENT HAZARD Failure to observe these instructions could lead to severe injury or death. To avoid injury to hands or fingers: <ul style="list-style-type: none"> • Always keep hands clear of rope, hook loop, hook and fairlead opening during installation, operation and when spooling in or out. • Always use extreme caution when handling hook and rope during spooling operations. 		

 WARNING	
	
CHEMICAL AND FIRE HAZARD Failure to observe these instructions could lead to severe injury or death. <ul style="list-style-type: none"> • Always remove jewelry and wear eye protection. • Never lean over battery while making connections. • Always verify area is clear of fuel lines, fuel tank, brake lines, electrical wires, etc. when drilling. • Never route electrical cables: <ul style="list-style-type: none"> - Across any sharp edges. - Through or near moving parts. - Near parts that become hot. • Always insulate and protect all exposed wiring and electrical terminals. • Always install terminal boots as directed in installation instructions. 	

 WARNING
Failure to observe these instructions could lead to property damage, severe injury, or death <ul style="list-style-type: none"> • Never exceed the maximum recommended hydraulic pressure or flow for any of the components used. • Always connect the winch to the hydraulic system as shown in the hydraulic schematic. • Always use the correct type of control valve as shown in the hydraulic schematic. • Always Stand clear of hydraulic lines during operation. • Always install hydraulic components in accordance with manufacturer's recommendations.



CAUTION

MOVING PARTS ENTANGLEMENT HAZARD

Failure to observe these instructions could lead to minor or moderate injury.

General Safety:

- **Always** know your winch. Take time to fully read the *Installation and Operations Guide* in order to understand your winch and its operation.
- **Never** operate this winch if you are under 16 years of age.
- **Never** operate this winch when under the influence of drugs, alcohol or medication.
- **Never** exceed winch or rope capacity listed on product data sheet. Double line using a snatch block to reduce winch load.

Installation Safety:

- **Always** choose a mounting location that is sufficiently strong to withstand the maximum pulling capacity of your winch.
- **Always** use factory approved mounting hardware, components, and accessories.
- **Always** use grade 8 or better mounting hardware.
- **Never** weld mounting bolts.
- **Always** use care when using longer bolts than those supplied from factory. Bolts that are too long can damage the base and/or prevent the winch from being mounted securely.
- **Always** position fairlead with WARNING label on top.
- **Always** prestretch wire rope and respool under load before use. Tightly wound wire rope reduces chances of "binding", which can damage the rope.





CAUTION

MOVING PARTS ENTANGLEMENT HAZARD

Failure to observe these instructions could lead to minor or moderate injury.

- **Always** inspect, rope, hook, and slings before operating winch. Damaged components must be replaced before operation. Protect parts from damage.
- **Never** hook rope back onto itself. This damages the rope.
- **Always** use a choker chain, choker rope, or tree trunk protector on the anchor.
- **Always** remove any element or obstacle that may interfere with safe operation of the winch.
- **Always** take time to use appropriate rigging techniques for a winch pull.
- **Always** be certain the anchor you select will withstand the load and the strap or chain will not slip.
- **Never** engage or disengage clutch if winch is under load, rope is in tension or drum is moving.
- **Always** double line or pick distant anchor point when rigging. This maximizes pulling power and avoids overloading the winch.
- **Never** winch with less than 5 wraps of rope around the drum. The rope could come loose from the drum.
- **Never** touch rope or hook while in tension or under load.
- **Never** touch rope or hook while someone else is at the control switch or during winching operation.
- **Always** stand clear of rope and load and keep others away while winching.
- **Always** be aware of stability of vehicle and load during winching. Alert all bystanders of any unstable condition.

 CAUTION	
	
<p>CUT AND BURN HAZARD</p> <p>Failure to observe these instructions could lead to minor or moderate injury.</p> <p>To avoid injury to hands and fingers:</p> <ul style="list-style-type: none"> • Always wear heavy leather gloves when handling a wire rope. • Never let rope slip through your hands. • Always be aware of possible hot surface at winch motor, drum or rope during or after winch use. 	

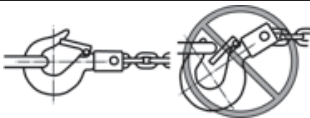
 CAUTION

<p>MOVING PARTS ENTANGLEMENT HAZARD</p> <p>Failure to observe these instructions could lead to minor to moderate injury.</p> <ul style="list-style-type: none"> • Always use a hook with a latch • Always insure hook latch is closed and not supporting load. • Never apply load to hook tip or latch. Apply load only to the center of hook. • Never use a hook whose throat opening has increased, or whose tip is bent or twisted.

 WARNING	
	
<p>FALLING OR CRUSHING HAZARD</p> <p>Failure to observe these instructions could lead to severe injury or death.</p> <ul style="list-style-type: none"> • Never use winch to lift or move persons. • Never use winch as a hoist or to suspend a load. 	

NOTICE
<p>AVOID WINCH AND EQUIPMENT DAMAGE</p> <ul style="list-style-type: none"> • Always avoid side pulls which can pile up rope at one end of the drum. This can damage rope or winch. • Always ensure the clutch is fully engaged or disengaged. • Never use winch to tow other vehicles. Shock loads can momentarily exceed capacity of rope and winch. • Always use care to not damage the vehicle frame when anchoring to a vehicle during a winching operation. • Never "jog" rope under load. Shock loads can momentarily exceed capacity of rope and winch. • Never use winch to secure a load during transport. • Never submerge winch in water. • Always store the remote control in a protected, clean, dry area.

What is a Winch?

WARN Industries produces a large family of winches and hoists. But what makes a winch different than a hoist?

Winches and hoists look alike. Both consist of a motor, a rotating drum with rope, reduction gears, a base, and usually an electrical control system. However, winches and hoists are used for different purposes.

Winches are used to pull a load horizontally across the ground, while hoists are used to lift a load into the air. Unlike hoists, the operator of a winch may unwind cable by "free spooling" or disengaging the motor from the gear train using the built-in clutch. Then the operator reverses the position of the clutch to connect the motor to the gears and pull the load.

Pre-Install Checklist

- 1 Check to see that you have received the following:
 - The winch
 - The winch mounting hardware
- 2 Upon removing winch from packaging, check for damage including bent or cracked tie rods, tie bars, or housings. Correct any damage before installing winch.
- 3 Make sure the environment surrounding winch and controller is free of :
 - Combustible vapors
 - Chemical fumes
 - Oil vapors
 - Corrosive material
- 4 Make sure that the air temperature surrounding the winch and controller stays within 120° F (49° C) and -20° F (-29° C).
- 5 Make sure that the mounting structure can withstand the full rated pull of the winch.

Mounting the Winch

Mounting Bolts:

Use the supplied fasteners whenever possible or SAE Grade 8 bolts of the same thread size. The tie plates, tensioner bracket, and spacers supplied with the winch should NOT be removed. Mounting brackets (if required) should be added to the tie plates and spacers supplied with the winch. Mounting brackets thicker than ½ inch (12mm) in thickness may require longer mounting bolts to be used. The bolt threads must extend a minimum of ¾ inch (19mm) into the drum supports. Bolts that are too long or too short will fail to anchor the winch securely and may cause a failure of the winch mounting.

Mounting Brackets:

When foot mounting the winch, the mounting plate should be a minimum of ½ inch thick steel. A thinner mounting plate will not support the winch properly and may cause a failure of the winch mounting. Foot mounting plates thicker than 1/2 inch (12mm) will require longer mounting bolts.

When side mounting the winch, brackets must be a minimum of 4 inch (100mm) by 4 inch (100mm) by ½ inch (12mm) thick angle iron or larger. Mounting brackets with inadequate thickness may cause a failure of the winch mounting. Side mounting brackets thicker than 1/2 inch (12mm) will require longer mounting bolts.

- 1 Make sure that the mounting surface is flat within +/-0.020 in. (0.50 mm). If the surface is not flat, use shim stock as needed to avoid straining the winch.
- 2 Torque all mounting bolts to the recommended values on the product data sheet.
- 3 Use the mounting hole locations provided on the product data sheet.

Mounting Configurations

This section illustrates the recommended mounting configurations for the Series XL winch. This section does not include every possible mounting configuration, but illustrates the correct methods for mounting the winch.

Foot Down Mounting Position:

DO NOT wind the rope from the top of the drum.
DO NOT position the load direction away from the mounting surface.

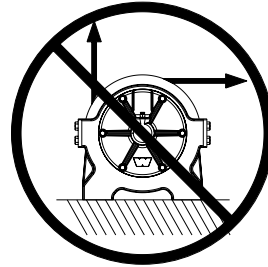

Foot Down Mounting Position:

DO wind the rope from the bottom of the drum.

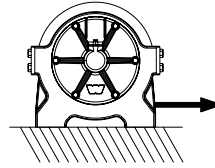

Foot Forward Mounting Position:

DO wind the rope from the top or bottom of the drum towards the direction of the mounting surface.

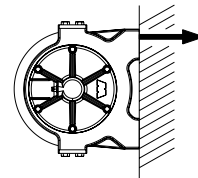

Side Mount:

DO wind the rope from the top of the drum.

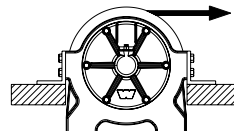

Mounting Bolt Patterns

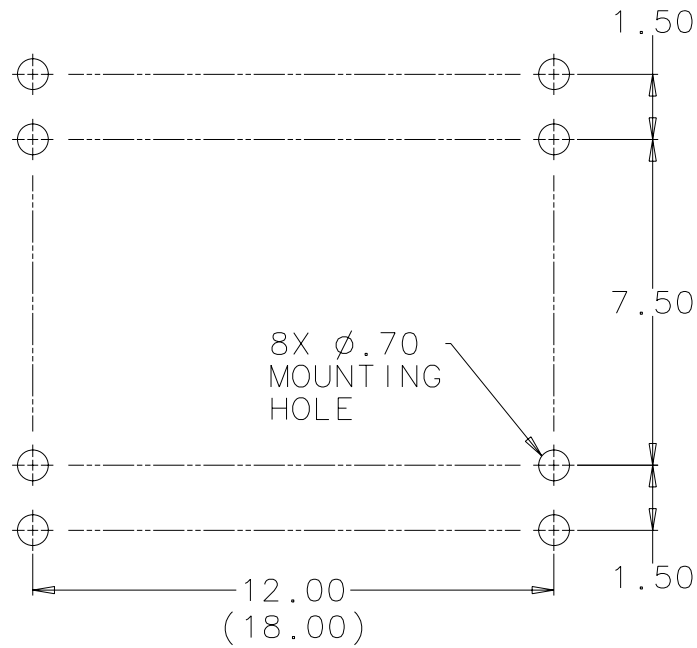

BOLT PATTERN- SERIES XL FOOT MOUNTING
STANDARD DRUM (LONG DRUM)

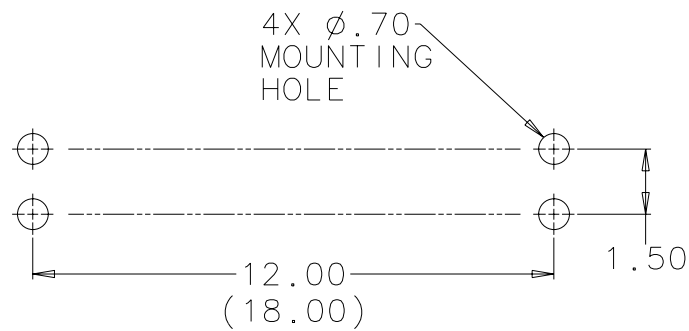

BOLT PATTERN- SERIES XL SIDE MOUNTING
STANDARD DRUM (LONG DRUM)

Hydraulic Winches: General Information

NOTE: The hydraulic system diagram and component descriptions are provided for general reference. Consult a knowledgeable hydraulics representative for specific recommendations on component selection, interconnection, layout, and best practice.

The pressure rating of the winch motor is determined by (a) the maximum allowable pressure at the motor inlet port and (b) the maximum allowable pressure drop across the motor. Pressure drop is defined as the difference between the inlet port pressure and the outlet port pressure at the winch motor. Exceeding the maximum inlet pressure may damage the winch motor. Exceeding the maximum pressure drop may cause failure of winch components.

The recommended operating temperature range of the hydraulic motor is 100°F to 150°F (38°C to 66°C). The maximum operating temperature range is -6°F to 180°F (-21°C to 82°C). Do NOT exceed the flow rating of the hydraulic motor. See the product data sheet for specific hydraulic specifications.



WARNING

Failure to observe these instructions could lead to property damage, severe injury, or death

- **Never** exceed the maximum recommended hydraulic pressure or flow for any of the components used.
- **Never** use a relief valve that exceeds the hydraulic motor pressure rating. Use of the incorrect relief valve can overload the winch or cause hose or fitting failure.
- **Always** use an open-center type control valve (A & B work ports drain to tank) to ensure proper brake operation.
- **Always** make sure all hydraulic system components are functioning correctly.

HYDRAULIC FLUID: The hydraulic fluid used with the winch must be an extreme pressure, anti-wear hydraulic oil with oxidation and corrosion inhibitors. It must contain a foam suppressant, and have a viscosity rating of 100-300 SUS at 60°F to 115°F (15°C to 46°C). The recommended nominal filtration level is 10 microns or finer.

HYDRAULIC SYSTEM SCHEMATIC
SERIES XL WINCHES

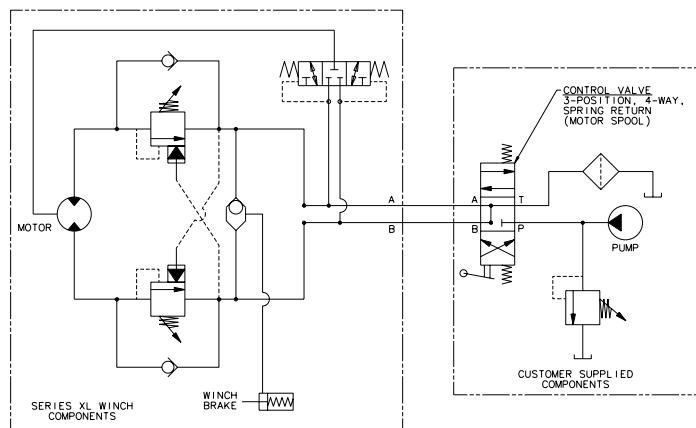

Brake System

WARN Series XL winches are equipped with a 2-part hydraulic braking system.

- 1 Dual counterbalance valves mounted to the winch motor provide dynamic braking to control the load when it is moving (i.e. power out function).
- 2 A spring applied hydraulically released (SAHR) disc brake prevents movement of the winch drum and load when the winch is stopped (i.e. control valve OFF position).

Both braking components are designed to operate in either direction, which allows flexibility in the rope winding direction.

Never attempt to adjust or remove the Counterbalance Valves installed in the winch hydraulic manifold.

In order for the brake system to function properly, the winch must be connected to the proper system Control Valve. The Control Valve must be a 3-position, 4-way, spring return valve as shown in the Hydraulic Schematic. The Control Valve and hydraulic plumbing must allow both motor ports (Port A and Port B) to drain freely to the hydraulic system reservoir in the center (OFF) position. Hydraulic system back pressure (return line pressure) must not exceed 100 psi. Use of the incorrect control valve or plumbing may cause failure of the brake system.

Freespool Clutch Operation

WARN Series XL winches are equipped with either a manual or air operated freespool clutch depending on the model. The freespool clutch allows the operator to rapidly spool out the wire rope. The freespool clutch disconnects the winch drum from the winch brake.

MANUAL CLUTCH OPERATION

The manual freespool clutch is operated by depressing the detent latch and turning the clutch lever as indicated on the winch label.

AIR CLUTCH OPERATION

The air freespool clutch is operated by application of air pressure to the fitting supplied on the winch gearbox housing. The fitting is designed to accept ¼" rigid plastic tubing.

1. To release the clutch (freespool operation):
Apply 50-120 psi air pressure to the air fitting.
2. To engage the clutch (winch operation):
Remove air pressure (0 psi) from the air fitting.



WARNING

Failure to observe these instructions could lead to property damage, severe injury, or death.

- **Always** ensure the clutch is fully engaged before operating the winch.
- **Never** release the clutch under load.
- **Never** operate the winch motor for a prolonged period while the clutch is in freespool mode.
- **Never** exceed 120 psi air pressure.
- **Never** use oil or other liquids to operate the air clutch.

Installation Final Check

- Recheck mounting hardware for loose bolts, etc.
- Be sure all hydraulic system components and connections are correct
- Be sure all connections are tight and secure
- Check motor rotation: The drum should rotate counterclockwise when viewed from the motor end when hydraulic fluid is supplied to Port A of the motor.
- To ensure maximum hydraulic motor life, the winch should be operated for one hour at no more than 30% of rated load before application of full load.



WARNING

Failure to observe these instructions could lead to property damage, severe injury, or death.

- **Always** maintain a minimum of five (5) wraps of rope on the drum.
- **Always** use wire rope specified on the product data sheet.
- **Always** install rope according to the illustration below.

Installing the Wire Rope

The wire rope may be spooled on the winch drum in either direction. Always follow the guidelines for pull direction listed under *Mounting the Winch*.

- 1 Insert the end of the wire rope into the anchor hole in the drum flange. **NOTE:** A small piece of tape around the end of the wire rope will make installation much easier. The wire rope must extend to the other end of the hole.
- 2 Torque the set screws to 12-15 lb-ft (16-20 N-m). Do not overtighten as this may cause the screw threads to be damaged. Ensure both (2) set screws secure the wire rope. Ensure both (2) set screws do not protrude from the drum flange.
- 3 With end of rope securely installed, carefully wind the rope evenly onto the drum. Keep the rope under tension at all times.
- 4 Always maintain a minimum of five (5) wraps of rope on the drum. Fewer wraps may cause the end of the rope to pull free of the drum and drop the load.

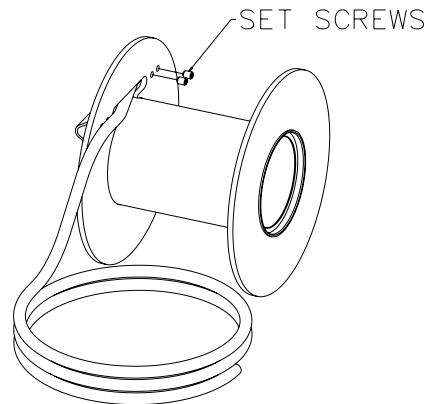

Anchoring Wire Rope on Drum

Operating Instructions

 WARNING
<p>Failure to observe these instructions could lead to property damage, severe injury or death.</p> <p>Always watch for hazards from the cable, drum pinch points, uncontrolled loads, and rope or rigging under tension.</p>

- **Never** touch rope or rigging while pulling a load, while anyone is at controls, or while operating winch.
- **Never** put rope around an object and hook it back on itself. This will damage the rope.
- **Never** use winch with less than five (5) wraps of rope around winch drum. The cable anchor is not designed to hold the rated load. The rope may pull free and release the load with fewer than five wraps of rope on the winch drum.
- **Never** let the rope slip through your hands.

Safe Operating Procedures

NEVER:

- **Never** place any part of your body or clothing near rotating or moving parts. Rotating drum with rope under tension can create a pinch point.
- **Never** handle ropes or operate winch without wearing eye protection and heavy gloves.
- **Never** stand close to winch when operating. If rope breaks it can fly back with tremendous force.
- **Never** lift, pull, or otherwise transport people with winch.
- **Never** lift, pull, support or otherwise transport loads over people.
- **Never** attempt to pull loads greater than rated capacity of the winch.
- **Never** pull a load until it jams and causes the drum and motor to stall.
Note: The two conditions above produce excess load on the winch. Excess loads may cause winch, rope or structural failure. Excess loads can create undetectable damage, which may cause the winch to fail even when pulling loads within its rated capacity.
- **Never** allow hydraulic system or gearbox to overheat.

ALWAYS:

- **Always** inspect and carefully rewind rope after each use. Cuts, kinks, or frayed areas reduce the tensile strength of rope. Replace rope if damaged.
- **Always** inspect hydraulic system connections before using winch.
- **Always** stand clear of the rope and load during winch operation.
- **Always** make sure that other winch operators understand the potential hazards and have been trained in proper use of the winch.
- **Always** make sure that the control valve and winch assembly are installed, operated, adjusted, and serviced by qualified personnel familiar with its construction and operation.

Spooling Guidelines

Stretching wire rope

The life of a wire rope directly relates to its use and to the care it receives. A new wire rope must be "stretched" or spooled onto the drum under a load of at least 500 lb. (227 kg.). The objective of "stretching" is to produce tight even wraps on the inner and outer layers of the rope, thus preventing damage to the rope from binding and kinking.

To accomplish the stretching operation, follow the guidelines and safety precautions in the Basic Guide to Winching Techniques. Set up your vehicle and winch for a straight-line pull on flat ground. Spool out all but the last five wraps. Attach the rope to an anchor point or load. Operate the winch using the remote switch as you sit in the driver's seat keeping light pressure on the brake. Spool the final few feet of rope while gripping the hook with a hook strap.

Spooling out

Freespooling is generally the quickest and easiest way to spool out wire rope. Before freespooling, power out enough rope to remove any tension the rope may be under. Disengage the clutch. Now freespool by manually pulling out enough wire rope for the winching operation. Always leave at least 5 wraps on the drum.

Spooling in under load

Never exceed the rated line pull of the winch.

Power in the wire rope evenly and tightly on the drum. This prevents the outer wire wraps from drawing into the inner wraps, binding, and damaging the wire rope.

Avoid shock loads when spooling by using the control switch intermittently to take up wire rope slack. Shock loads can momentarily far exceed the winch and wire rope ratings. The maximum recommended fleet angle (side pull angle) is 5 degrees. Exceeding the recommended fleet angle will cause damage to the winch drum and/

or rope tensioner. A suitable fairlead must be mounted for pulling angles that exceed 5 degrees.

Spooling in under no load

Assisted - Have your assistant hold the hook with the hook strap putting as much constant tension on the wire rope as possible. While keeping tension, the assistant should walk toward the winch while you operate the control switch. Release the switch when the hook is 8 ft. (2.4 m.) from the fairlead opening. Spool in the remainder for storage.

Unassisted - Arrange the wire rope to be spooled so it will not kink or tangle when spooled. Be sure any wire rope on the drum is tightly and evenly layered. Spool enough wire rope to complete the next full layer on the drum. Tighten and straighten the layer. Repeat the process until the hook is 8 ft. (2.4 m) from the fairlead opening. Spool in the remainder for storage.

Spooling remainder for storage

Secure the hook to a suitable anchor point near the winch. Carefully power in the remaining wire rope, jogging the control switch to take up the last of the slack. Be careful to not over tighten or damage may occur to the wire rope or anchor point.

Periodic Preventive Maintenance

- Keep winch free of dirt, oil, grease, water and other substances. Remove any overflow grease from bearings.
- Check all mounting bolts and make sure they are tightened to proper torque. Replace any damaged fasteners.
- Periodically check all hydraulic connections to be sure they are tight and free of corrosion.
- Check rope for visible damage every time winch is operated. Examples of damage are: cuts, knots, mashed or frayed portions, and broken strands. Replace rope immediately if damaged. Failure to replace a damaged rope could result in breakage.
- If winch drum continues to turn after controls are released, brake may need to be replaced.

Preventive maintenance schedule

Maintenance activity	After first operation	Before each use	Semi-annually or after each 25 hours of operation
Check fasteners	X		X
Check hydraulic connections	X		X
Spool out and check rope		X	
Check motor brushes			X
Visual check of winch and control valve	X	X	X

NOTE: Hydraulic system failures typically follow the same pattern: a gradual or sudden loss of pressure or flow resulting in a loss of motor power. Any one of the system components may be at fault. Refer to the table for general recommendations. If necessary, consult a knowledgeable hydraulics representative.

NOTE: See product data sheet for hydraulic specifications.

Trouble Shooting:

Note: These trouble shooting tips apply to Series XL hydraulic winches only. Repair activities should only be performed by qualified persons.

	WARNING
PERSONAL INJURY	
Failure to observe these instructions could lead to severe injury or death.	

Problem	Possible cause	Corrective action
Winch does not hold load when stopped	Load exceeds winch rating	Refer to the product data sheet for the correct line pull rating for your winch.
	Brake is badly worn or broken	Replace brake. NOTE: Entire brake assembly must be replaced.
	Incorrect hydraulic control valve installed	Verify that the hydraulic control valve is an "open-center" type spring return valve and that all hydraulic pressure to the winch is released in the OFF position.
Difficulty unspooling rope	Bent flange on drum	Rotate drum and inspect for bent flanges. Bent drum must be removed and repaired.
	Worn drum bushings	Remove drum. Inspect bushings and replace if necessary.
	Freespool clutch is not fully disengaged	Verify that clutch lever rotates freely. Verify that clutch lever is turned to the release position. Verify that air pressure to the clutch is 50-120 psi (air clutch only).
	Clutch is damaged	Disassemble winch and verify that driveshaft moves freely and that the driveshaft spring is not damaged. Verify that piston O-ring is not damaged (air clutch only).
	Rope is bound up on drum	Connect the winch to a load and alternately power-in and power-out. The rope will usually work itself free. Inspect the rope for damage and replace if necessary. USE EXTREME CAUTION.
	Drum binds, because improper mounting causes winch to twist	Remount the winch following specifications and procedures in this manual. Be sure mounting surface is flat to within .020 inch. Use shims if necessary. Be sure mounting bolts are tight.
	Ambient temperature too low	Run the winch for several minutes to warm the gearbox to operating temperature.

WARN Industrial Winches

Problem	Possible cause	Corrective action
Winch lacks power, pulls slowly, stalls or will not run at all.	Hydraulic fluid pressure too low or flow rate too low	Check fluid level, filter, valves, and other components. Consult a hydraulic specialist.
	Drum binds, because improper mounting causes winch to twist	Remount the winch following specifications and procedures in this manual. Be sure mounting surface is flat to within .020 inch. Use shims if necessary. Be sure mounting bolts are tight.
	Freespool clutch is not engaged	Verify that clutch lever rotates freely. Verify that clutch lever is turned to the correct position. Verify that air pressure to the clutch is 0 psi (air clutch only).
	Worn drum bushings	Remove drum. Inspect bushings and replace if necessary.
	Gearbox wear, binding, or internal damage	Disassemble winch gearbox. Inspect for damaged components, free rotation of planet gears, binding, or contamination. Replace damaged components and lubricate with EP grease.
	Hydraulic motor is damaged	Replace hydraulic motor.
	Disc brake is not released	Verify that hydraulic pressure is applied to disc brake during winch operation. Replace brake if necessary. NOTE: Entire brake assembly must be replaced.
	Damage or contamination of hydraulic manifold	Replace hydraulic manifold. NOTE: Entire manifold assembly must be replaced. DO NOT attempt to adjust or remove the counterbalance valves.
Ambient temperature too low	Temperature must be above -6° F for the hydraulic system to function properly.	

Customer Support

Should you have any questions about this product or these instructions, please call WARN's customer service through the numbers below, Monday through Friday between 7:00 AM and 4:00 PM Pacific Time for assistance. Or for e-mail support, visit our web site www.WARN.com and click on customer service section.

Note: Only qualified persons should undertake repair activities on WARN winches.

United States	International
Phone: 503-722-1200 or 800-543-9276 (US only)	Phone 503-722-3008
FAX: 503-722-3000	FAX: 503-722-3005

Warranty

WARN® Commercial Products Limited One (1) Year Warranty Statement

Warn Industries, Inc. (WARN) warrants to the original purchaser that the mechanical components and electrical components of the "WARN" Products specified below will be free of defects in material and workmanship for a period of one (1) year from the original date of purchase. This Warranty applies only to the original purchaser of the Products. To obtain any warranty service, you must provide WARN with proof of purchase and date of purchase acceptable to WARN, such as a copy of your purchase receipt. This warranty does not cover the removal or reinstallation of the Product. WARN will, at its option, repair, replace or refund the purchase price of a defective Product or component, provided you return the defective Product or component during the warranty period, transportation charges prepaid, to Warn Industries Service Department or a Factory Authorized Service Center. Attach your name, address, telephone number, a description of the problem, and a copy of your receipt and original bill of sale bearing the WARN serial number of the defective Product and date of purchase.

This warranty does not apply (i) to parts or components excluded below, or (ii) if the Product has been damaged by accident, abuse, misuse, collision, overloading, modification, misapplication, improper installation, or improper service. This warranty is void if any WARN serial number has been removed or defaced.

THE WARRANTY SET FORTH ABOVE IS THE ONLY WARRANTY. THERE ARE NO OTHER WARRANTIES, EXPRESS OR IMPLIED, INCLUDING BUT NOT LIMITED TO IMPLIED WARRANTIES OF MERCHANTABILITY OR FITNESS FOR A PARTICULAR PURPOSE.

ANY IMPLIED WARRANTY WHICH BY LAW MAY NOT BE EXCLUDED IS LIMITED IN DURATION TO ONE (1) YEAR FROM THE DATE OF ORIGINAL RETAIL PURCHASE OF THE PRODUCT.

WARN SHALL NOT BE LIABLE FOR SPECIAL, INDIRECT, INCIDENTAL OR CONSEQUENTIAL DAMAGES (INCLUDING, BUT NOT LIMITED TO, LOST PROFITS, DOWN TIME OR LOSS OF USE) UNDER ANY LEGAL THEORY, EVEN IF WARN WAS ADVISED OF THE POSSIBILITY OF SUCH DAMAGES.

Some states do not allow the exclusion of implied warranties or the exclusion or limitation of liability for incidental or consequential damages, or limitations on how long an implied warranty lasts, so the above limitation or exclusion may not apply to you. This warranty gives you specific legal rights. You may also have other rights that vary from state to state.

WARN reserves the right to change Product design without notice. In situations in which WARN has changed a Product design, WARN shall have no obligation to upgrade or otherwise modify previously manufactured Products.

No WARN dealer, agent or employee is authorized to make any modification, extension or addition to this warranty.

Warranty inquires and Products returned for warranty service should be sent to:

WARN INDUSTRIES, INC.
Customer Service Department
12900 SE Capps Road
Clackamas, OR 97015
1-800-543-WARN (1-800-543-9276)

Products covered by this warranty
WARN Series XL winches

Products not covered by this warranty
Product paint and finish including corrosion damage
Wire Rope