



# Winch Installation and Operator's Guide

Every winching situation has the potential for personal injury. In order to minimize that risk, it is important to read this guide and *The Basic Guide to Winching Techniques* carefully. Please familiarize yourself with the operation of your winch before using it, and be constantly safety oriented. In this guide, we will set forth many of the basic rules of safe winch operation. Please read *The Basic Guide to Winching Techniques* for more information on your winch and proper rigging techniques. Remember, because every winching situation is different, your constant good judgment and consistent focus on safety are of great importance.

**TABLE OF CONTENTS:**

**SAFETY**

Symbol Index..... 2

General Safety Precautions ..... 3-5

Safe Working Conditions ..... 6

**INSTRUCTIONS**

Mounting Winch..... 7

Electrical Connections ..... 8

Operating Instructions ..... 9-10

Stretching Wire Rope ..... 10-11

**Warn Industries Inc.**  
 12900 SE Capps Road  
 Clackamas, OR 97015  
 USA

Customer Service: (800) 543-WARN  
 (9276)  
 International: (503) 722-1200  
 Fax: (503) 722-3000

SYMBOL	EXPLANATION
	Read the Instruction Manual
	Always Wear Hearing and Eye Protection
	Never Use Winch as a Hoist
	Properly Seat Load in Throat of Hook
	Wind Rope on Bottom of Drum
	Finger/Fairlead Crushing Hazard
	Hand Piercing/Cutting Hazard
	Explosion/Bursting Hazard
	Sharp Edge Hazard
	Use hook larger than 1/2" (13mm)



SYMBOL	EXPLANATION
	Always Wear Leather Gloves
	Do Not Move People
	Always Use Supplied Hook Strap
	Never Apply Load to Hook Tip or Latch
	Never Wind Rope Over Top of Drum
	Fairlead Pinch Point
	Hot Surface Hazard
	Fire and Burn Hazard
	Moving Parts Hazard



## Warnings and Cautions

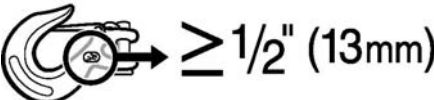

As you read these instructions, you will see WARNINGS, CAUTIONS, NOTICES and NOTES. Each message has a specific purpose. WARNINGS are safety messages that indicate a potentially hazardous situation, which, if not avoided could result in serious injury or death. CAUTIONS are safety messages that indicate a potentially hazardous situation which, if not avoided, could result in minor or moderate injury. A CAUTION may also be used to alert against unsafe practice. CAUTIONS and WARNINGS identify the hazard, indicate how to avoid the hazard, and advise of the probable consequence of not avoiding the hazard. NOTICES are messages to avoid property damage. NOTES are additional information to help you complete a procedure. **PLEASE WORK SAFELY!**

 <b>WARNING</b>	
	
<b>MOVING PARTS ENTANGLEMENT HAZARD</b> Failure to observe these instructions could lead to serious injury or death.	
<b>General Safety:</b> <ul style="list-style-type: none"> <li>• <b>Always</b> Know Your Winch. Take time to fully read the Instructions and/or Operations Guide, and/or Basic Guide to Winching Techniques, in order to understand your winch and its operations.</li> <li>• <b>Never</b> exceed winch or winch rope rated capacity. Double line using a snatch block to reduce winch load.</li> <li>• <b>Always</b> wear heavy leather gloves when handling winch rope.</li> <li>• <b>Never</b> use winch or winch rope for towing. Shock loads can damage, overload and break rope.</li> <li>• <b>Never</b> use a winch to secure a load.</li> <li>• <b>Never</b> operate this winch when under the influence of drugs, alcohol or medication.</li> <li>• <b>Never</b> operate this winch if you are under 16 years of age.</li> <li>• <b>Always</b> ensure the operator and bystanders are aware of the stability of the vehicle and/or load.</li> <li>• <b>Always</b> pass remote lead thru window when used in vehicle.</li> </ul>	
<b>Installation Safety:</b> <ul style="list-style-type: none"> <li>• <b>Always</b> choose a mounting location that is sufficiently strong to withstand the maximum pulling capacity of your winch.</li> <li>• <b>Always</b> use grade 5 (grade 8.8 metric) or better hardware.</li> <li>• <b>Never</b> weld mounting bolts.</li> <li>• <b>Always</b> use factory approved mounting hardware, components, and accessories.</li> <li>• <b>Never</b> use bolts that are too long.</li> <li>• <b>Always</b> complete the winch installation and hook attachment before installing the wiring.</li> <li>• <b>Always</b> keep hands clear of winch rope, hook loop, hook and fairlead opening during installation, operation, and when spooling in or out.</li> <li>• <b>Always</b> position fairlead with warning readily visible on top.</li> <li>• <b>Always</b> prestretch rope and respool under load before use. Tightly wound rope reduces chances of "binding", which can damage the rope.</li> </ul>	

 <b>WARNING</b>	
	
	
<b>MOVING PARTS ENTANGLEMENT HAZARD</b> Failure to observe these instructions could lead to serious injury or death.	
<ul style="list-style-type: none"> <li>• <b>Always</b> use a hook marked 1/2" (13 mm) or larger with the M15000 and 16.5ti fairlead.</li> <li>• <b>Always</b> ensure hook latch is closed and not supporting load.</li> <li>• <b>Never</b> apply load to hook tip or latch. Apply load only to the center of hook.</li> <li>• <b>Never</b> use a hook whose throat opening has increased, or whose tip is bent or twisted.</li> <li>• <b>Always</b> use a hook with a latch.</li> <li>• <b>Always</b> keep wired remote control lead and power cord clear of the drum, rope, and rigging. Inspect for cracks, pinches, frayed wires or loose connections. Damaged components must be replaced before operation.</li> </ul>	



 <b>WARNING</b>	
	
<b>MOVING PARTS ENTANGLEMENT HAZARD</b> Failure to observe these instructions could lead to serious injury or death.	
<b>Winching Safety:</b> <ul style="list-style-type: none"> <li>• <b>Always</b> inspect winch rope, hook, and slings before operating winch. Frayed, kinked or damaged winch rope must be replaced immediately. Damaged components must be replaced before operation. Protect parts from damage.</li> <li>• <b>Always</b> remove any element or obstacle that may interfere with safe operation of the winch.</li> <li>• <b>Always</b> be certain the anchor you select will withstand the load and the strap or chain will not slip.</li> <li>• <b>Always</b> use supplied hook strap whenever spooling winch rope in or out, during installation and during operation.</li> <li>• <b>Always</b> require operators and bystanders to be aware of vehicle and or load.</li> <li>• <b>Always</b> be aware of stability of vehicle and load during winching, keep others away. Alert all bystanders of an unstable condition.</li> <li>• <b>Always</b> unspool as much wire rope as possible when rigging. Double line or pick distant anchor point.</li> <li>• <b>Always</b> take time to use appropriate rigging techniques for a winch pull.</li> <li>• <b>Never</b> touch winch rope or hook while someone else is at the control switch or during winching operation.</li> <li>• <b>Never</b> engage or disengage clutch if winch is under load, winch rope is in tension or drum is moving.</li> <li>• <b>Never</b> touch winch rope or hook while under tension or under load.</li> <li>• <b>Always</b> stand clear of winch rope and load and keep others away while winching.</li> <li>• <b>Never</b> use vehicle to pull load on winch rope. Combined load or shock load can damage, overload and break rope.</li> <li>• <b>Never</b> wrap winch rope back onto itself. Use a choker chain or tree trunk protector on the anchor.</li> </ul>	

 <b>WARNING</b>	
	
	
<b>FALLING OR CRUSHING HAZARD</b> Failure to observe these instructions could lead to serious injury or death.	
<ul style="list-style-type: none"> <li>• <b>Always</b> stand clear, keep hands clear, keep others away.</li> <li>• <b>Never</b> operate winch with less than 5 wraps of rope around the drum. Rope could come loose from the drum, as the rope attachment to the drum is not designed to hold a load.</li> <li>• <b>Never</b> use winch as a hoist or to suspend a load.</li> <li>• <b>Always</b> be certain anchor will withstand load, use appropriate rigging and take time to rig correctly.</li> <li>• <b>Never</b> use winch to lift or move persons.</li> <li>• <b>Never</b> use excessive effort to freespool winch rope.</li> <li>• <b>Always</b> use proper posture/lifting technique or get lifting assistance while handling and installing product.</li> <li>• <b>Always</b> spool the rope onto the drum in the direction specified by the winch warning label on the winch and/or documentation. This is required for the automatic brake (if so equipped) to function properly.</li> <li>• <b>Always</b> spool the winch rope onto the drum as indicated by the drum rotation label.</li> </ul>	

 <b>WARNING</b>	
	
<b>CUT AND BURN HAZARD</b> Failure to observe these instructions could lead to serious injury or death.	
<b>To avoid injury to hands and fingers:</b> <ul style="list-style-type: none"> <li>• <b>Always</b> wear heavy leather gloves when handling winch rope.</li> <li>• <b>Always</b> be aware of possible hot surfaces at winch motor, drum or rope during or after winch use.</li> </ul>	

 <b>WARNING</b>	
	
	
<b>CHEMICAL AND FIRE HAZARD</b>	
<p>Failure to observe these instructions could lead to serious injury or death.</p> <ul style="list-style-type: none"> <li>• <b>Always</b> remove jewelry and wear eye protection.</li> <li>• <b>Never</b> route electrical cables across sharp edges.</li> <li>• <b>Never</b> route electrical cables near parts that get hot.</li> <li>• <b>Never</b> route electrical cables through or near moving parts.</li> <li>• <b>Always</b> place the supplied terminal boots on wires and terminals as directed by the installation instructions.</li> <li>• <b>Never</b> lean over battery while making connections.</li> <li>• <b>Never</b> route electrical cables over battery terminals.</li> <li>• <b>Never</b> short battery terminals with metal objects.</li> <li>• <b>Always</b> verify area is clear of fuel lines, fuel tank, brake lines, electrical wires, etc., when drilling.</li> <li>• <b>Always</b> consult operator's manual for proper wiring details.</li> <li>• <b>Always</b> insulate and protect all exposed wiring and electrical terminals.</li> </ul>	

 <b>CAUTION</b>	
	
<b>CUT AND BURN HAZARD</b>	
<p>Failure to observe these instructions could lead to minor or moderate injury.</p> <ul style="list-style-type: none"> <li>• <b>Never</b> let winch rope slip through your hands.</li> </ul>	

 <b>CAUTION</b>	
	
<b>MOVING PARTS ENTANGLEMENT HAZARD</b>	
<p>Failure to observe these instructions could lead to minor or moderate injury.</p> <p>To avoid injury to hands or fingers:</p> <ul style="list-style-type: none"> <li>• <b>Never</b> leave remote control where it can be activated during free spooling, rigging, or when the winch is not being used.</li> <li>• <b>Never</b> leave the winch remote control plugged in when installing, freespooling, rigging, servicing or when the winch is not being used.</li> </ul>	

<b>NOTICE</b>
<b>AVOID WINCH AND EQUIPMENT DAMAGE</b>
<ul style="list-style-type: none"> <li>• <b>Always</b> avoid side pulls which can pile up wire rope at one end of the drum. This can damage wire rope or winch.</li> <li>• <b>Always</b> ensure the clutch is fully engaged or disengaged.</li> <li>• <b>Always</b> use care to not damage the vehicle frame when anchoring to a vehicle during a winching operation.</li> <li>• <b>Never</b> submerge winch in water.</li> <li>• <b>Always</b> store the remote control in a protected, clean, dry area.</li> </ul>

 <b>WARNING</b>
<p><b>Always</b> stand clear, keep hands clear, keep others away.</p>

 <b>WARNING</b>
<p><b>Always</b> require operators and bystanders to be aware of vehicle and or load.</p>

 <b>CAUTION</b>
<p><b>Never</b> leave remote control where it can be activated during free spooling, rigging, or when the winch is not being used.</p>

<b>NOTICE</b>
<p><b>Never</b> submerge winch in water.</p>

**SAFE WORKING CONDITIONS**

The operator should always operate the winch from a safe position when pulling a load. The safe areas are: (1) Perpendicular to the wire rope, (2) Inside the vehicle with the hood up (if winch is mounted on front of vehicle). These safe positions will help prevent the wire rope from striking the operator if the wire rope fails when under load.

Operate winch from the fully extended remote control cord length whenever possible. The operator must always be at least 8 ft. (2.44 m) from the winch while operating. This will prevent entanglement with the fairlead and keep the operator out of harms way during winch load pulling.

**Never** work around the wire rope while under load.

**Sound Emissions**

The winch is designed so that the sound emissions do not exceed 70 dBA from the operator's station. The operator must be at least 8 ft. (2.44 m) from the winch while operating. If the winch is exceeding 70 dBA from the operator's station, have the winch inspected at an authorized service center.

**Cleaning**

Do not direct high pressure water (pressure washers, car washes, etc.) between the drum support and drum flange or clutch lever.

Use low pressure water and a soapy rag or sponge to clean the winch.

Avoid using chemicals that may damage the finish.

Thoroughly clean salt residue from the winch as soon as possible to minimize corrosion.

**Maintenance**

No lubrication is required for the life of the winch unless the winch has been submerged in water. If this occurs, a qualified service center must complete service as soon as possible to prevent corrosion damage. If the control pack is submerged, it must be replaced when the winch is serviced.

Check battery cables and electrical connections at 90 day intervals to be certain they are clean and tight at all connection points.

Inspect the wire rope before and after each winching operation. When damaged, replace with the size specified in the Replacement Parts List, or go to the Warn website at [www.warn.com](http://www.warn.com).

The wire rope must always spool onto the drum as indicated by the drum rotation decal on the winch.

## MOUNTING WINCH

### MOUNTING WINCH

Choose a mounting location that is sufficiently strong enough to withstand the loads you intend to winch. Only the mounting orientations shown are possible for safe winching operation. All others are improper and inappropriate. The use of recommended bolt and lock washer combinations torqued to recommended levels will prevent vibration during operation. The mounting details indicate the proper torque levels.

Remember the winch rope must always spool onto the drum as indicated by the drum rotation decal.

Refer to the following diagrams for proper mounting orientation.

### Mounting Bolt Pattern:

Standard: 10" x 4.5", 254 mm x 114.3 mm

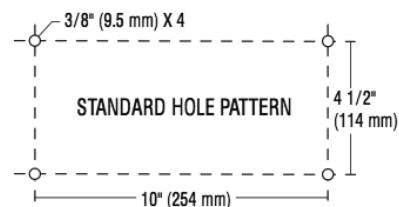

### Control Pack Installation

Mount the control pack according to the instructions included in the WARN mounting system kit. Use the bracket included in the kit.

The control pack mounting fasteners may also be moved to the unused holes in the control pack base plate for additional mounting flexibility.

Plate Thickness	Bolt Length
5/16" (8 mm)	1.5" (40 mm)
3/8" (10 mm)	1.5" (40 mm)
1/2" (13 mm)	1.75" (45 mm)

#### ⚠ WARNING

Always choose a mounting location that is sufficiently strong to withstand the maximum pulling capacity of your winch.

#### ⚠ WARNING

Always complete the winch installation and attach the hook before installing the wiring.

#### ⚠ WARNING

Never use bolts that are too long.

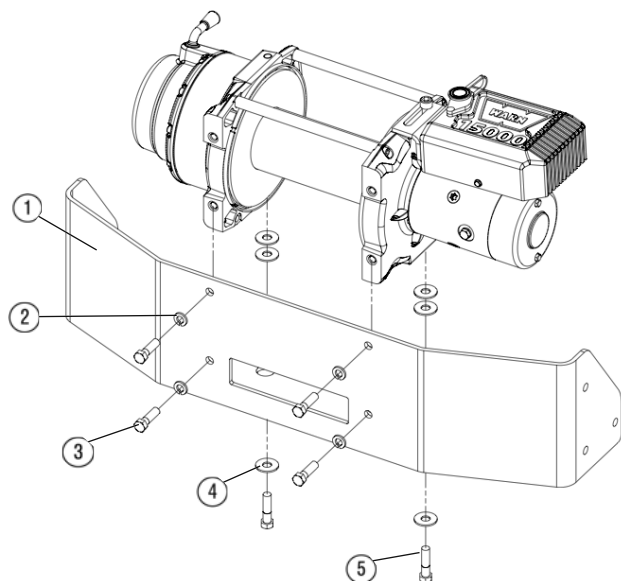

## ELECTRICAL CONNECTIONS

#### ⚠ WARNING

Never route electrical cables across sharp edges.

#### ⚠ WARNING

Never route electrical cables near parts that get hot.

#### ⚠ WARNING

Never route electrical cables through or near moving parts.

#### ⚠ WARNING

Always place the supplied terminal boots on wires and terminals as directed by the installation instructions.

#### ⚠ WARNING

Always insulate and protect all exposed wiring and electrical terminals.

### ELECTRICAL CONNECTIONS

Use the included insulating boots on exposed connections to prevent electrical shorting. Route battery connection cables in areas which will not cause them to chafe or cut through the insulation causing a potential short circuit.

Upon completion of installation, check winch for proper operation.

### Electrical Diagrams:

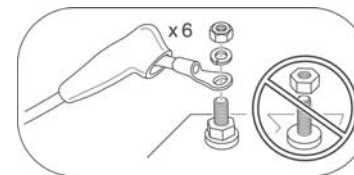

### Battery Recommendations

A fully charged battery and good connections are essential to the proper operation of your winch. The minimum requirement for a 12 volt DC battery is 650 Cold Cranking Amps.

Pin #	Color
1	Brown
2	Green
3	Black
4	White
5	Blue
6	Red

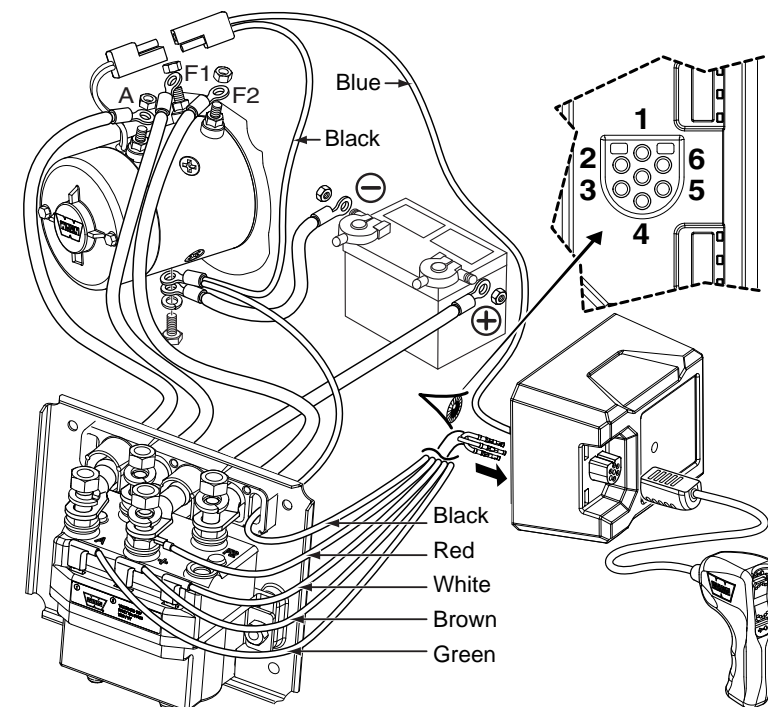



**Remote Control Switch**

Do not leave the remote plugged into the winch when not in use. Leaving the remote plugged in, may result in a dangerous condition and/or battery drain.

**Vertical/Horizontal Remote:**

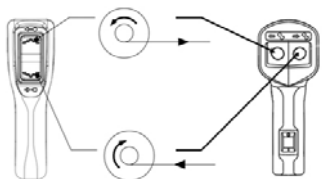

**Clutch Operation**

When the clutch is engaged, the gear train is coupled to the wire rope drum and power can be transferred from the winch motor. When the clutch is disengaged it is in the freespool position and the gear train and wire rope drum are uncoupled allowing the drum to rotate freely.

The clutch lever, located on the winch housing opposite the motor, controls the clutch position. To prevent damage, always fully engage or fully disengage the clutch lever.

**Disengaged:**

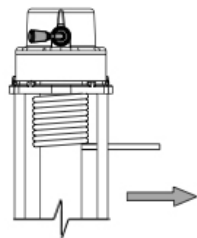

**Engaged:**

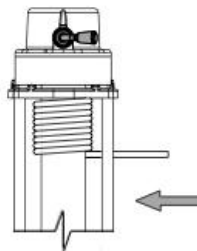

**Spooling Out**

Freespooling is generally the quickest and easiest way to spool out wire rope. Before freespooling wire rope out from the winch, power out enough rope to remove any tension the wire rope might be under. Disengage the clutch. Then freespool by manually spooling out enough wire rope for the winching operation. See *The Basic Guide to Winching Techniques* for more information.

Always leave at least 5 wraps of rope on the drum.

**Spooling In Under Load**

Never exceed winch's rated line pull.

Power-in the wire rope evenly and tightly on the drum. This prevents the outer wire wraps from sinking into the inner wraps, binding, and damaging the wire rope.

Avoid shock loads when spooling, by pulsing the control switch to take up wire rope slack. Shock loads can momentarily far exceed the winch and rope ratings.

**Spooling In Under No Load**

*Spooling with an Assistant:* Have the assistant hold the hook strap putting as much constant tension on the wire rope as possible. While keeping tension, the assistant should walk toward the winch while you operate the control switch spooling in the wire rope. Release the switch when the hook is a minimum of 6 ft. (2 m) from the fairlead opening.

Spool in the remainder for storage as directed below.

*Spooling Alone:* Arrange the wire rope to be spooled so it will not kink or tangle when spooled. Be sure any wire rope on the drum is tightly and evenly layered. Spool enough wire rope to complete the next full layer on the drum. Tighten and straighten the layer.

**WARNING**  
Always take time to fully understand your winch and the winching operation by reviewing *The Basic Guide to Winching Techniques* included with your winch.

**WARNING**  
Never engage or disengage clutch if winch is under load, winch rope is in tension or drum is moving.

**WARNING**  
Never operate winch with less than 5 wraps of rope around the drum. Rope could come loose from the drum, as the rope attachment to the drum is not designed to hold a load.

**NOTICE**  
Do Not power-out rope more than 30 ft. without allowing the winch to cool for 20 minutes before powering rope back in. Instead, place the clutch in freespool and pull the rope off by hand.

**OPERATING INSTRUCTIONS**

**Cont.**  
Repeat process until the hook is a minimum of 6 ft. (2 m) from the fairlead opening.

Spool in the remainder for storage as directed below.

**Spooling Remainder for Storage**

When the hook is within 6 ft. (2 m) of the fairlead, disconnect the hook from the anchor or load. Hold onto the supplied hook strap and hold tension on the winch rope. Slowly power-in the winch by "pulsing" the power-in switch on the remote control until the hook is within 3 ft. (1 m) of the fairlead. Stop winching in and attach the hook to a suitable anchor point on the vehicle.

**DO NOT POWER THE HOOK INTO THE FAIRLEAD.**

This could cause damage to the fairlead. Once the hook is suitably attached to the vehicle, power-in the remaining slack in the winch rope by "pulsing" the power-in switch on the remote control until there is minimal slack in the winch wire rope.

**Overloading/Overheating**

This winch is rated for intermittent duty. When the motor approaches stall speed, very rapid heat buildup occurs which may cause motor damage.

Double-line rigging (see *The Basic Guide to Winching Techniques*) will reduce the amperage draw, and reduce heat buildup in the motor. This allows longer continual use.

**TI Motor Temperature Indicator**

When the motor reaches a temperature that could result in damage if the winch is operated for a long period of time, the LED in the remote will blink. Short periods of operation with the LED blinking will not damage the winch. Long periods of operation should be avoided.

**STRETCHING WIRE ROPE**

The life of a wire rope is directly related to the use and care it receives. During its first use, a new wire rope must be spooled onto its drum under a load of at least 1000 lbs. (454 kgs). Use the following instructions to properly stretch the wire rope onto the winch drum.

- 1) Choose a **FLAT AND LEVEL** location that is large enough to run out the entire length of wire rope.
- 2) Turn the clutch lever on the winch to the "Free Spool" position. Spool out the wire rope to the last 5 wraps on the drum. Once the wire rope is spooled out, turn the clutch lever on the winch to the "Engaged" position.
- 3) Attach the hook end of the rope to a suitable anchor point and back the vehicle away from the anchor point until there is very little slack in the wire rope. Before getting out of the vehicle, set the parking brake, place the vehicle in gear or park and turn the vehicle off.

- 4) Connect the remote control to the winch. Standing approximately 8 ft. (2.44 m) away from the winch, power-in the winch until all of the slack is wound onto the winch drum. Disconnect the remote control from the winch. Hold tension on the wire rope with one hand; carefully push the wire rope to the side of the drum the wire rope is attached to so there are no gaps between each coil on the drum. Be sure to check that the wire rope is winding off of the bottom of the drum, not the top, or the automatic load holding brake will not function properly. (If the wire rope is winding off the top you have powered the winch "out" instead of "in" on the remote control).

**WARNING**  
Always keep hands clear of winch rope, hook loop, hook and fairlead opening during installation, operation, and when spooling in or out.

**WARNING**  
Never touch winch rope or hook while someone else is at the control switch or during winching operation.

**WARNING**  
Always wear heavy leather gloves when handling winch rope.

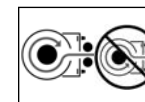

**WARNING**  
Always use supplied hook strap whenever spooling winch rope in or out, during installation or operation to avoid injury to hands and fingers.

## STRETCHING WIRE ROPE Cont.

**5)** The following steps should be done using two people for proper safety. If you attempt to tension your wire rope alone be sure to always engage the parking brake, place the transmission in gear and turn the vehicle off every time you exit the vehicle to inspect the winch wire rope. Never exit the vehicle with a load on the winch wire rope. Tensioning the wire rope is critical to ensure a long product life. Tensioning the wire rope will prevent outer layers of wire rope from pinching and deforming the inner layers.

**6)** Use care to evenly wrap each layer to prevent damage to the rope.

**7)** Pass the remote control through the driver's window for the driver of the vehicle to operate. Instruct your assistant to stand to the side of the vehicle and away from the winch wire rope. Your assistant should signal you if the wire rope is winding correctly by watching it move across the fairlead as the wire rope is powered in. Start the vehicle and place the transmission in neutral. Release the parking brake while applying moderate brake pedal pressure. Press power-in on the remote control switch. After winching in for approximately 6 ft. (2 m), stop winching. Slowly let up off of the brake pedal and then apply the parking brake. This will ensure that there is no load on the winch rope. Then place the transmission in

park or in gear and turn the vehicle off. Exit the vehicle and inspect the winch to make sure that the wire rope is being evenly wound onto the winch drum and not sinking into the lower layer. If the wire rope is sinking, power the wire rope out and repeat this step from the beginning with more brake pedal pressure.

**8)** When you are convinced the wire rope is winding onto the winch drum properly, repeat step 6 until the vehicle is within 6 ft. (2 m) of the winch anchor. Once within 6 ft. (2 m), slowly let up off of the brake pedal and then apply the parking brake. This will ensure that there is no load on the winch wire rope. Then place the transmission in park or in gear and turn the vehicle off. Exit the vehicle. Disconnect the hook from the anchor. While holding onto the supplied hook strap, hold tension on the winch rope and slowly power-in the winch by "pulsing" the power-in switch on the remote control until the hook is within 3 ft. (1 m) of the fairlead. Stop winching in and attach the hook to a suitable anchor point on the vehicle.

**DO NOT POWER THE HOOK INTO THE FAIRLEAD.** This could cause damage to the fairlead. Once the hook is suitably attached to the vehicle, power-in the remaining slack in the winch rope by "pulsing" the power-in switch on the remote control until there is minimal slack in the winch wire rope.

**⚠ WARNING**  
Always prestretch rope and respool under load before use. Tightly wound rope reduces chances of "binding", which can damage the rope.

**⚠ WARNING**  
Never touch rope or hook while someone else is at the control switch or during winching operation.

**⚠ WARNING**  
Never operate winch with less than 5 wraps of rope around the drum. Rope could come loose from the drum, as the rope attachment to the drum is not designed to hold a load.