



WINCH USER GUIDE

WARN Works® 3000ACI Utility Winch

Part Number: 66327



Your safety, and the safety of others, is very important. To help you make informed decisions about safety, we have provided installation and operating instructions and other information on labels and in this guide. This information alerts you to potential hazards that could hurt you or others. It is not possible to warn you about all potential hazards associated with this product, you must use your own good judgment.

CARELESS WINCH INSTALLATION AND OPERATION CAN RESULT IN SERIOUS INJURY OR EQUIPMENT DAMAGE. READ AND UNDERSTAND ALL SAFETY PRECAUTIONS AND OPERATING INSTRUCTIONS BEFORE INSTALLING AND OPERATING THIS PRODUCT.

This guide identifies potential hazards and has important safety messages that help you and others avoid personal injury or death. **WARNING** and **CAUTION** are signal words that identify the level of hazard. These signal words mean:

⚠ WARNING signals a hazard that *could* cause serious injury or death, if you do not follow recommendations.

⚠ CAUTION signals a hazard that *may* cause minor to moderate injury, if you do not follow recommendations.

This guide uses **NOTICE** to call attention to important mechanical information, and **Note**: to emphasize general information worthy of special attention

Product Description: WARN Works® 3000ACI Utility Winch

The WARN Works® 3000ACI Utility Winch is a powerful; pulling tool. Powered by a 115 or 230 volt AC power source this compact winch has a pulling capacity of 3000 pound / 1361 kilos.

The units has a station types control switch for power in and power out operation, 100" of 5/16" wire rope and clasp hook. A freespooling clutch is a standard option.

Introduction

Thank you for choosing WARN Works® for your utility winch needs. All WARN Works® products have been designed and manufactured for many years of problem-free operation. For future reference please record the following information:

Model/Part Number: _____ **Date of Purchase:** _____

Before you begin

- Read the instructions completely to familiarize yourself with the installation process.
- Review all the notices, cautions and warnings to make sure the kit will be installed correctly and safely.

Safety Precautions

The following are general safety precautions that every winch operator should know. Taking precedence over any specific rule listed here, however, is the most important rule of all—**USE COMMON SENSE**.

A few minutes spent reading these rules can make an operator aware of dangerous practices to avoid and precautions to take for his own safety and the safety of others. Frequent examinations and periodic inspections of the equipment as well as conscientious observance of safety rules may save lives as well as time and money.

WARNING

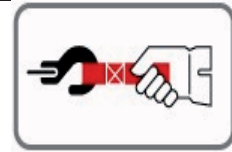
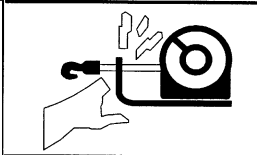

MOVING PARTS ENTANGLEMENT HAZARD

Failure to observe these instructions could lead to severe injury or death.

To avoid injury to hands or fingers.

- **Always** keep hands clear of wire rope, hook loop, hook and fairlead opening during installation, operation and when spooling in or out.
- **Always** use extreme caution when handling hook and wire rope during spooling operations.
- **Always** use supplied hook strap whenever spooling wire rope in or out, during installation or operation to avoid injury to hands or fingers.

WARNING

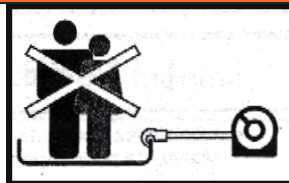

FALLING OR CRUSHING HAZARD

Failure to observe these instructions could lead to severe injury or death.

- **Never** use as an overhead hoist, or to suspend a load.
- **Never** use to lift or move persons.

Safety Precautions - continued

CAUTION

MOVING PARTS ENTANGLEMENT HAZARD

Failure to observe these instructions could lead to minor to moderate injury.

General Safety:

- **Always** Know Your Winch: Take time to fully read and understand the included Installation and Operations guide, and Basic Guide to Winching Techniques, in order to understand your winch and the winching operation.
- **Never** operate this winch if you are under 16 years of age.
- **Never** operate this winch when under the influence of drugs, alcohol or medication.
- **Never** exceed winch or wire rope rated capacity. Double line using a snatch block to reduce winch load.

Installation Safety:

- **Always** choose a mounting location that is sufficiently strong to withstand the maximum pulling capacity of your winch.
- **Always** use factory approved switches, remote controls, accessories and installation components.
- **Always** use grade 5 or better hardware, never weld bolts and never use longer bolts than those supplied from factory.
- **Always** complete winch mounting and attachment of hook to hook loop before wiring winch during installation.
- **Always** position fairlead with WARNING label on top.
- **Always** spool the wire rope onto the drum as indicated by the drum rotation label on the winch. Required for automatic brake to work (if winch is so equipped) and for correct installation orientation.
- **Always** prestretch wire rope and respool under load before use. Tightly wound wire rope reduces chances of "binding", which is wire rope working it's way down into a loosely wound wire rope layer, and catching or damaging itself.

Winching Safety:

- **Always** inspect winch installation and wire rope and hook condition before operating winch. Frayed, kinked or damaged wire rope must be replaced immediately. Loose or damaged winch installation must be corrected immediately.
 - **Never** hook wire rope back onto itself. This damages the wire rope. Always use a choker chain, wire choker rope or tree trunk protector on the anchor.
 - **Always** prior to winching, remove any element that may interfere with safe winch operation.
 - **Always** take your time when rigging for a winch pull.
 - **Always** be certain the anchor you select will withstand the load, and the strap or chain will not slip.
 - **Never** engage or disengage clutch if winch is under load, wire rope is in tension or wire rope drum is moving.
 - **Always** unspool as much wire rope as possible when rigging. Double line or pick distant anchor point.
 - **Never** winch with less than 5 wraps of wire rope around the drum, the wire rope could come loose from the drum.
 - **Always** stand clear of wire rope and load during operation.
 - **Never** touch wire rope or hook while in tension or under load.
 - **Never** touch wire rope or hook while someone else is at the control switch or during winching operation.
 - **Never** touch wire rope or hook while remote control is plugged into winch.
 - **Always** stand clear of wire rope and load and keep others away while winching.
- Always require operator and bystanders to be aware of stability during winching of vehicle and/or load.
- **Always** keep remote control lead clear of the drum, wire rope and rigging. Inspect for cracks, pinches, frayed wires or loose connections. Replace if damaged.

Safety Precautions - continued

CAUTION



CUT AND BURN HAZARD

Failure to observe these instructions could lead to minor to moderate injury.

To avoid injury to hands and fingers:

- **Always** wear heavy leather gloves when handling a wire rope.
- **Never** let wire rope slip through your hands.
- **Always** be aware of possible hot surface at winch motor, drum or wire rope during or after winch use.

CAUTION

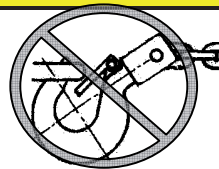
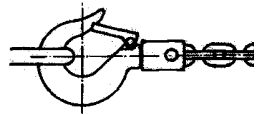

Moving Parts Entanglement Hazard

Failure to observe these instructions could lead to minor to moderate injury.

- **Never** apply load to hook tip or latch. Apply load only to the center of hook.
- **Never** use a hook whose throat opening has increased, or whose tip is bent or twisted.

NOTICE

AVOID WINCH AND EQUIPMENT DAMAGE

- **Always** avoid continuous side pulls, which can pile up wire rope at one end of the drum. This can damage your wire rope or winch.
- **Always** ensure the clutch is fully engaged or Disengaged.
- **Never** use winch to tow other vehicles. Shock loads can momentarily exceed capacity of wire rope & winch
- **Always** use care to not damage your frame when anchoring your vehicle during a winching operation.
- **Never** "jog" wire rope under load. Shock loads can momentarily exceed capacity of wire rope and winch.
- **Never** use winch to secure a load during transport.
- **Never** submerge winch in water.
- **Always** store the winch in a protected, clean, dry area.

Parts List

The WARN Works® 3000ACI Utility Winch consists of the following main components.

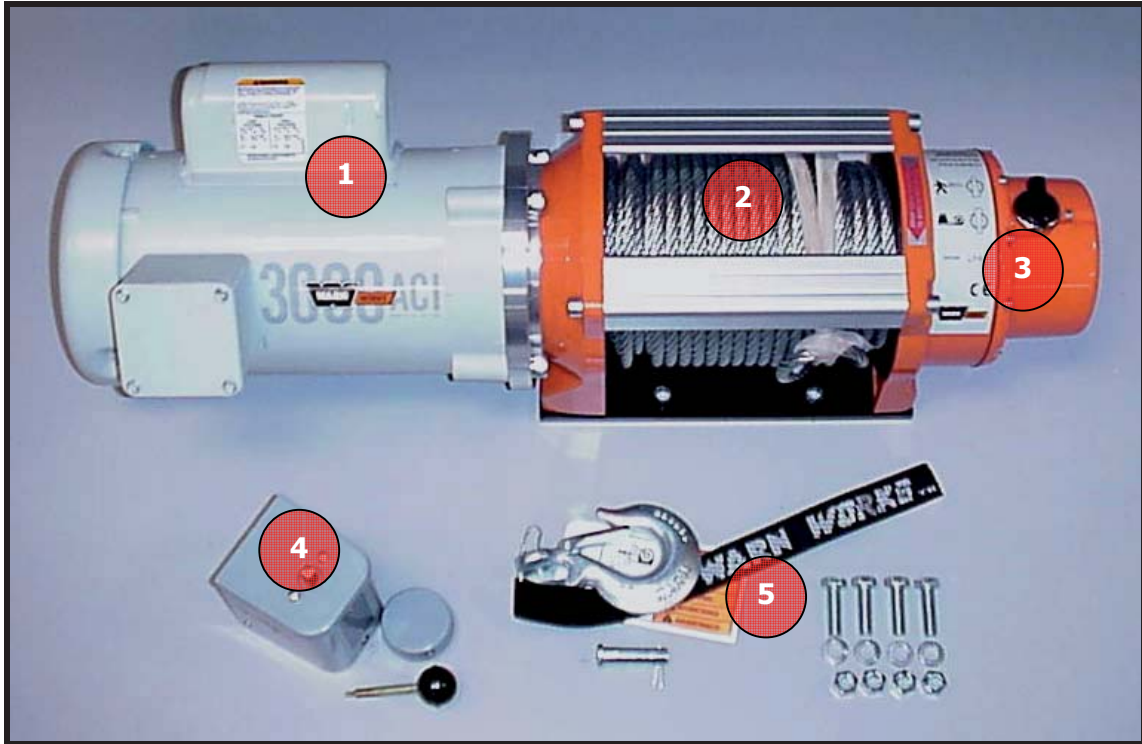

1. Powerfull .75 hp TEFC Induction Motor	2. Large Drum with 100" of 5/16 Cable
3. 3-Stage Planetary Geartrain with clutch	4. Station type control switch
5. Hardware Pack With Clasp Hook	

Dimensional Data for the Works 3000ACI

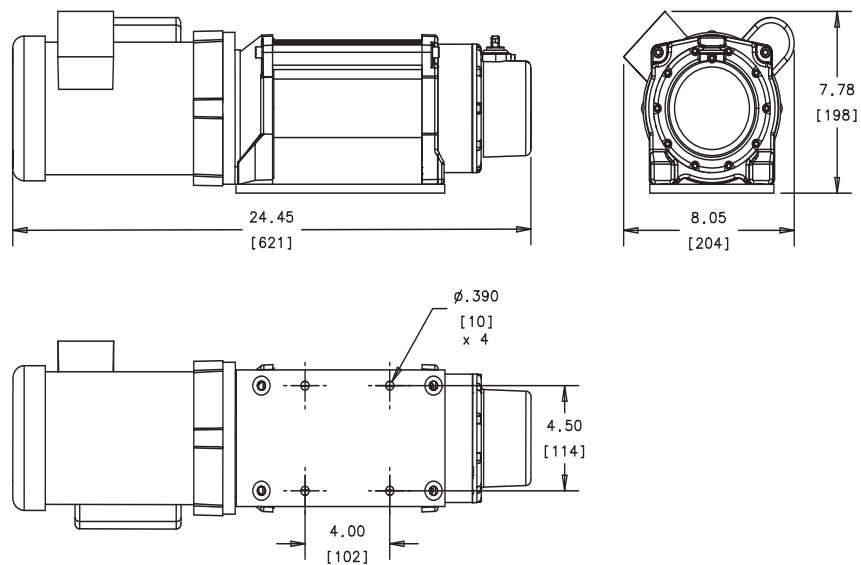

Specification Data for the Works 3000ACI

Features			
Pulling Capacity	3000lbs. (1361 kg)	Brake	Dynamic and Mechanical braking
Switch Type	GE Drum Switch CR102A1 Station Type	Warranty	1 year limited
Motor	TEFC Induction AC Motor	Wire Rope	5/16" X 100' (18.3 m)
HP	.75 HP 56C	Drum Diameter	2.5" (6.35 cm)
Power	120V 60 Hz or 230V 50Hz Single Phase AC	Fairlead	None
Gear Train	3-Stage planetary	Hole Pattern	4 holes
Gear Ratio	216:1	Electrical Leads	None
Clutch	Lever actuated sliding ring gear	Weight	76 lbs. (34.5 kg.)

Performance Data for the Works 3000ACI

PERFORMANCE DATA: 3000ACI						115V 60Hz Single Phase		
Load		Current		Speed		Pulling Power by Wire Rope Layer		
Lbs.	Kg	Amps	KW	Ft/min	M/min	Layer	lbs.	kg
0	0	9.1	1049	12.2	3.7	1	3000	1361
1000	453.6	11.0	1265	8.8	2.7	2	2700	1225
1500	680.4	12.7	1461	8.8	2.7	3	2460	1116
2000	907.2	14.8	1702	8.6	2.6	4	2250	1021
2500	1134	17.7	2036	8.5	2.6	5	2070	939
3000	1360.8	20.9	2300	8.1	2.5			

PERFORMANCE DATA: 3000ACI						230V 50Hz Single Phase		
Load		Current		Speed		Pulling Power by Wire Rope Layer		
Lbs.	Kg	Amps	KW	Ft/min	M/min	Layer	lbs.	kg
0	0	4.6	1058	12.2	3.7	1	3000	1361
1000	453.6	5.5	1265	8.8	2.7	2	2700	1225
1500	680.4	6.4	1472	8.8	2.7	3	2460	1116
2000	907.2	7.4	1702	8.6	2.6	4	2250	1021
2500	1134	8.9	2047	8.5	2.6	5	2070	939
3000	1360.8	10.5	2415	8.1	2.5			

Winch Installation to fixed location



Caution

Winch Failure Hazard

Failure to observe these instructions could lead to minor or moderate injury.

- Always choose a mounting location that is sufficiently strong to withstand the loads you intend to winch

The 3000ACI can be mounted to a fixed location by utilizing the mounting hole pattern for the winch unit. First, choose a mounting location that is sufficiently strong enough to withstand the loads you intend to winch.

Next, drill 4 holes to the dimensions specified in the drawing below.

Mounting Plate Hole Pattern

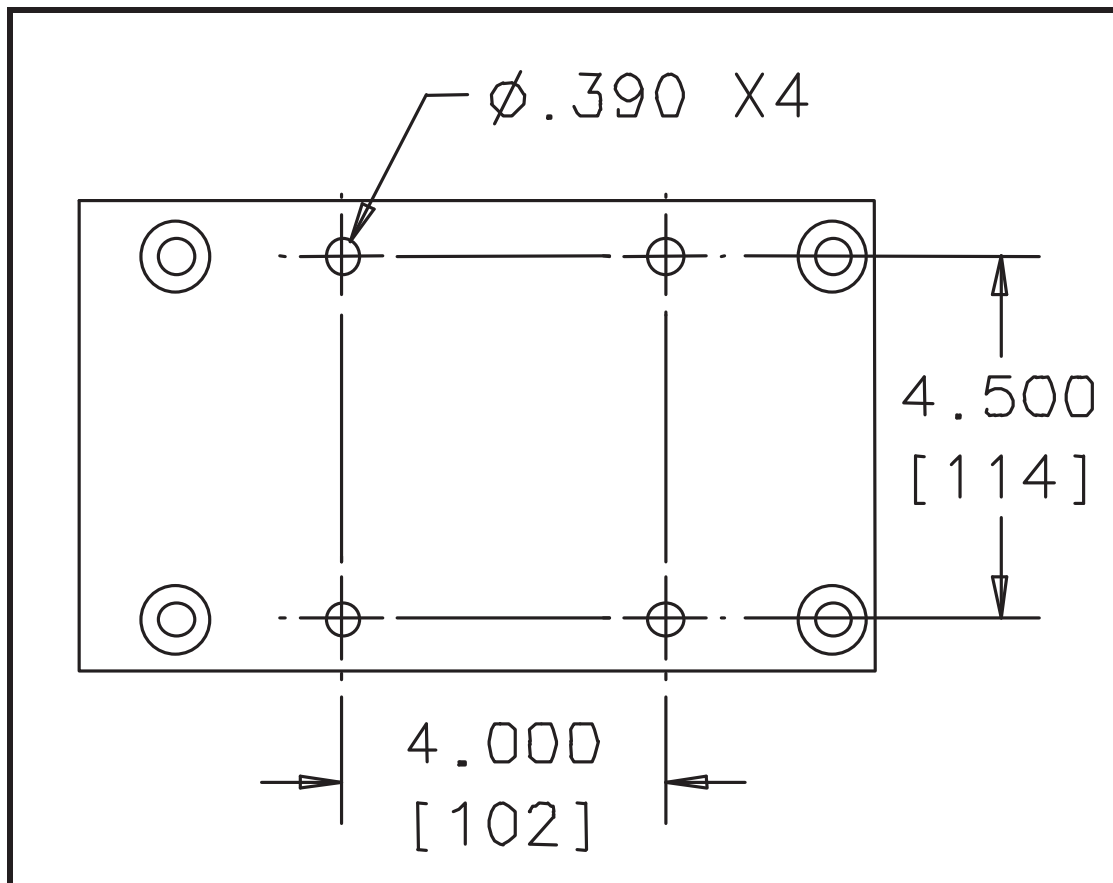

Winch Installation to a fixed location- continued

To secure the winch, always use:

- A flat, secure mounting location at least 3/16 in. (4.8 mm) thick steel.
- 3/8 in. lockwasher x 3.
- 3/8-18 x 1in. long, hex head capscrew, Grade 5 or better x 3.
- Torque mounting bolts to 30-35 ft-lbs (41-47 Nm).

Bolt length may need to be longer than specified above depending upon the thickness of the material the winch is mounted to.

Acceptable Mounting Position

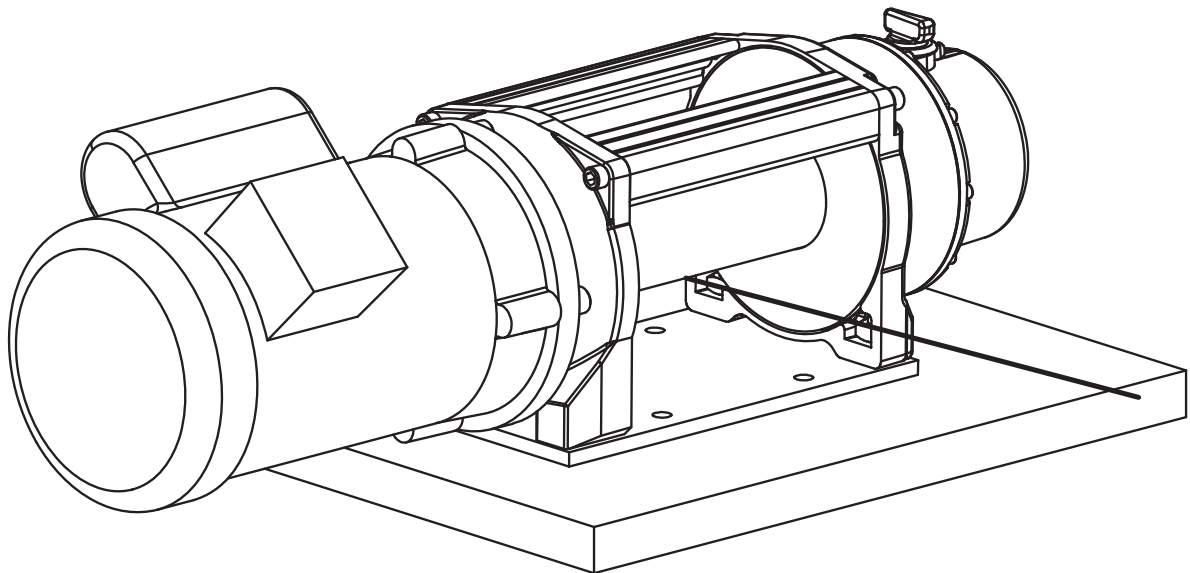

Wiring Instructions



Warning

Shock Hazard

Failure to observe these instructions could lead to severe injury or death.



- ❑ Always have the winch wired by a qualified electrician
- ❑ Always wire the winch in accordance with all local building and electrical codes.
- ❑ Always use properly grounded 115 / 230 V AC receptacle protected by a ground fault circuit interrupter (GFCI).
- ❑ Never operate this AC product in a wet environment.

Always have the winch wired by a qualified electrician and always wire the winch in accordance with all local building and electrical codes.

Winch Motor

Refer to the wiring diagram on the winch motor housing for the proper way to wire the motor to either 115 volt or 230 volt AC power source. A copy of those instructions and diagrams are inserted below for reference. Always defer to the actual diagrams that are on the winch motor and in the Drum Switch.

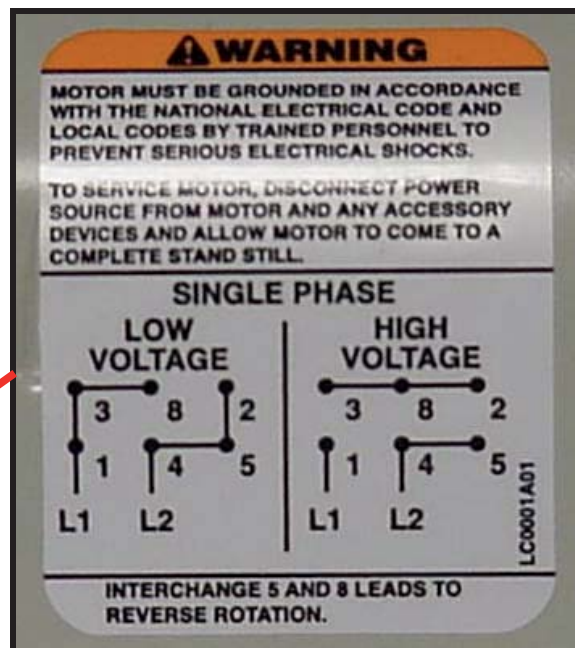

Wiring Instructions-continued

Switch Instructions

Refer to instructions enclosed with "GE Drum Switch CR102A1 diagram for wiring schematics. A copy of those instructions and diagrams are inserted below for reference. Always defer to the actual diagrams that are on the winch motor and in the Drum Switch.

Caution: Before installing in a nuclear application, determine that the product is intended for such use.

Warning : Disconnect power before installing or servicing.

Installation:

1. Mount the switch to a flat surface.
2. Connect the switch in accordance with the wiring diagram provided in the instructions or in the cover of the switch.

Note: Motor branch circuit protection should be provided in accordance with the national electrical code and local codes or ordinances.

Convertibility (Maintained to Momentary)

To convert the CR102A1 drum switch or similar switches from "Maintained Contact" to "Spring Return to OFF", remove the operating knob (6) from the hub(7) by turning in a counter clockwise motion. Pry the hub from the shaft. Turn the handle 180 degrees and replace the handle, knob and the hub to the switch.

Mechanism Assembly

To disassemble the switch, remove the handle, hub cover plate and stationary contacts. Remove the two screws holding the case top and then lift off the case top. Rotor assembly can then be removed.

Caution: Roller (3) is spring loaded and is loose in arm (4). Caution must be exerted not to loose the roller. Remove the roller from arm (4). To reassemble, place the roller in the arm (4). Place the rotor in the case by engaging the roller(3) with the cam and inserting the shaft in the hole at the bottom of the case. Reassemble by reversing the above procedure

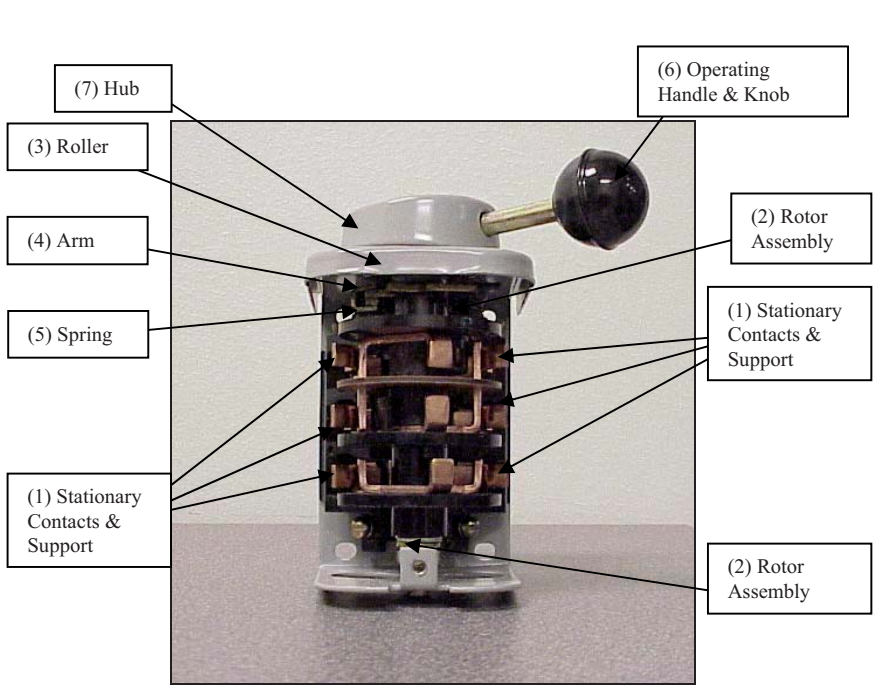
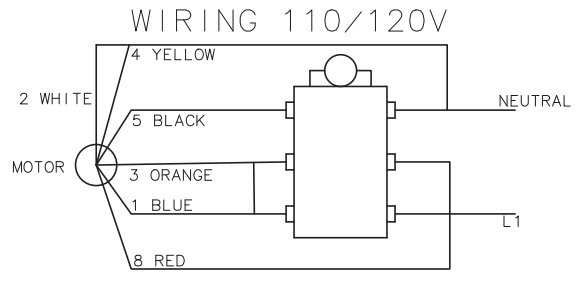
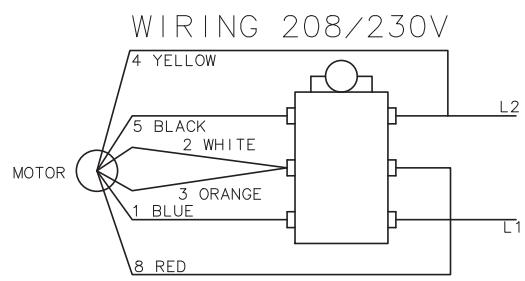

Figure 1. CR102A1

Wiring Diagram for 3000ACI and CR102A1



Wiring Instructions-continued

Switch Instructions

There is also a set of wiring diagrams inside the switch housing

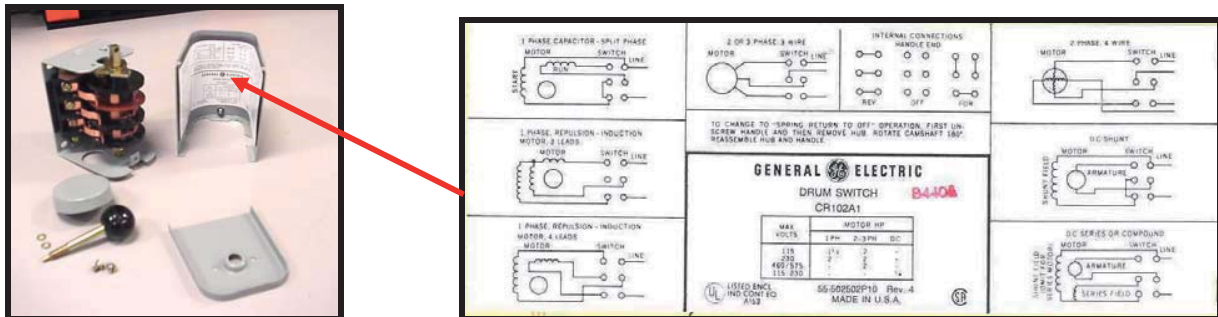

Convert GE Drum Switch CR102A1 to "Spring Return to OFF" configuration per instructions enclosed with switch.

Verify that all wiring is positioned so that the wire rope or moving load will not damage it.

Always de-energize circuit when winch is not in use.

Operating Instructions -

CLUTCH OPERATION



Warning

Winch Function Hazard

Failure to observe these instructions could lead to injury or property damage

- ❑ **Never engage or disengage the clutch if the winch is underload or wire rope is under tension.**

When the clutch is engaged the gear train is coupled to the wire rope drum and power may be transferred from the winch motor. When the clutch is in freespool the gear train and wire rope drum are uncoupled allowing the drum to rotate freely. The clutch lever, located on top of the motor, controls the clutch position. To prevent damage, always fully engage or fully disengage the clutch lever.

Disengage - Freespool

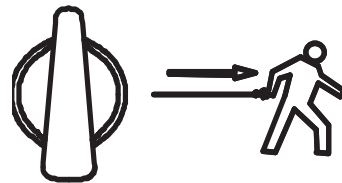

Engaged



Operating Instructions - continued



SPOOLING OUT

Freespooling is generally the quickest and easiest way to spool out wire rope. Before freespooling wire rope out from the winch, power out enough rope to remove any tension the wire rope may be under before disengaging the clutch. Now freespool by manually spooling out enough wire rope for the winching operation.

 CAUTION	
	
Personal Injury Hazard	
Failure to observe these instructions could lead to minor or moderate injury.	
<ul style="list-style-type: none"><input type="checkbox"/> Always wear leather gloves when handling wire rope<input type="checkbox"/> Never winch with less than 5 wraps of wire rope around the drum.	

STRETCHING THE WIRE ROPE

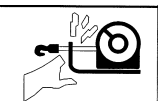
The life of a wire rope is directly related to the care and use it receives. During its first use, a new wire rope must be spooled onto its drum under a load of at least 500 lb. (227kg). Spool out the entire wire rope length leaving 5 wraps on the drum, then power in the wire rope under a load of 500 lb. (227kg) or more. This will stretch new wire rope and create a good wire wrap around the drum. Failure to do so may result in the outer wire wraps drawing into the inner wraps, binding, and damaging the wire rope.

 Warning	
Moving Parts Entanglement Hazard	
Failure to observe these instructions could lead to severe injury or death.	
 	<ul style="list-style-type: none"><input type="checkbox"/> ALWAYS keep hands clear of the wire rope, hook loop, hook and fairlead opening during installation, operation and when spooling in or out.<input type="checkbox"/> ALWAYS use supplied hook strap whenever spooling the wire rope in or out, during installation, or operation to avoid injury to hands or fingers.

Operating Instructions - continued

SPOOLING IN UNDER LOAD

- ❑ The wire rope must always spool onto the bottom of the drum as indicated by decal on the winch.
- ❑ Power in the wire rope evenly and tightly on the drum. This prevents the outer wire wraps from drawing into the inner wraps, binding and damaging the wire rope.
- ❑ Avoid shock loads when spooling, by using the control switch intermittently to take up wire rope slack. Shock loads can momentarily far exceed the winch and wire rope ratings.

SPOOLING IN UNDER NO LOAD

- ❑ **Assisted:** Have your assistant hold the hook with the hook strap putting as much constant tension on the wire rope as possible. While keeping tension, the assistant should walk toward the winch while you operate the control switch spooling in the wire rope. Release the switch when the hook is a minimum of 4 ft (1.2m) from the fairlead opening. Spool in the remainder for storage.
- ❑ **Unassisted:** Arrange the wire rope to be spooled so it will not kink or tangle when spooled. Be sure any wire rope on the drum is tightly and evenly layered. Spool enough wire rope to complete the next full layer on the drum. Tighten and straighten the layer. Repeat process until the hook is a minimum of 4ft (1.2m) from the fairlead. Spool in the remainder for storage.

SPOOLING REMAINDER FOR STORAGE

Keep hands clear of the wire rope, hook and fairlead opening. Always use the hook strap to hold hook when spooling under no load. Carefully power in the remaining wire rope, jogging the control switch to take up the last of the slack. Secure the hook to a suitable anchor point near the winch. Be careful not to overtighten or damage may occur to the wire rope or anchor point.

RIGGING

- ❑ Always spool out as much wire rope as possible when preparing rigging. Pick an anchor as far away as is practical; this provides the winch with its greatest pulling power.
- ❑ Rigging a double line with a snatch block will reduce the load on the winch to half without significant loss of spooling speed.
- ❑ Natural anchors such as trees, stumps and rocks are the handiest when available. Attach the choker chain, wire choker rope or tree trunk protector on the anchor as low as possible to avoid pulling the anchor down. If several possible anchors are available but they are not strong enough individually, it may be practical to attach a wire or chain choker around several anchors to form a strong collective anchor point.

Operating Instructions - continued

OVERLOADING/OVERHEATING

This winch is rated for intermittent duty. It should not be operated with the motor slowed down to a low RPM. When the motor approaches stall speed, a very rapid heat build-up occurs which may cause motor damage. Double line rigging will reduce the amperage draw from the motor allowing longer continual use (see rigging section).

Maintenance & Warranty

MAINTENANCE

- No lubrication is required for the life of the winch.
- Inspect the wire rope before and after each winching operation. Replace when damaged.

WARRANTY

see separate sheet packed with winch

-or-

If warranty sheet is lost or misplaced contact:

**Warn Industries, Inc.
Customer Service Dept.
12900 SE Capps Rd
Clackamas, OR 97015-8903.**

United States:

Phone: 503.722.1200 or (800) 543-9276 (US only)

Fax: 503.722-3000

International:

Phone: 503.722.3008

Fax: 503.722.3005

© 2005 Copyright Warn Industries, Inc. All rights reserved.

